

488 GTB





General remarks

This vehicle, which complies with EC homologation parameters, uses advanced technology and is capable of achieving high performance levels.

It is equipped with sophisticated active and passive safety systems (described below).

These safety features and systems do not authorise the driver to take risks other than those involved in normal driving since their preventive and protective action is guaranteed only in certain conditions. Unless otherwise instructed specifically by **FERRARI** (see the Safety chapter), the deactivation of any of the vehicle's safety systems is **PROHIBITED**.

While certain safety systems (e.g. the airbags) have been tested to ensure that they offer the highest possible levels of protection, they may nonetheless be hazardous in the event of failure by the driver or passenger to observe the instructions given by **FERRARI**. All vehicle occupants must be attentive at all times and take particular care when transporting passengers who are more subject to injury such as children, disabled and elderly persons.

Safe driving is subject to the following conditions **AT ALL TIMES**:

- the driver must be in perfect psycho-physical condition;
- road regulations (Traffic Regulations - Vienna Convention on Road Traffic that ended on 8 November 1968) must be strictly observed;
- common rules of caution must always be observed in relation to the quality/performance of the vehicle, driving conditions and contingent situations.

- Caution and discipline are the basis of safe driving.
- Driving takes place in a naturally dangerous context where a number of different risk factors interact. For this reason, it is important to drive bearing in mind that others, whether they are pedestrians, motorcyclists or motorists, can make mistakes. Keeping a safe distance allows emergency measures to be taken. Remember that national and international legislation requires that the driver of the vehicle must be capable of performing corrective and/or emergency manoeuvres at all times.
- Correct and careful use of a vehicle derives, above all, from respect for one's own safety and that of others as well as from compliance with road regulations. Only this respect will help you experience all the emotions that driving this car can offer you.

The driver **MUST NEVER** allow passengers to increase the risks associated with driving (e.g. by not using safety systems such as the seat belts) by failing to observe the mandatory safety rules that apply to both driver and passengers.

The vehicle **MUST NOT** be modified or tampered with for any reason whatsoever since, by so doing, the manufacturer's homologation and safety parameters will be modified.



The driver must pay the utmost attention to the signals of the vehicle and, in particular, the warning lights on the dashboard and buzzers. Even when the warning lights do not indicate a situation of immediate danger, the driver must be cautious in relation to possible consequences/degeneration of the failure and other information given.

During routine operations, such as refuelling, precautions should always be taken and it is important to check that flammable liquid has not been spilled; these precautions must be observed even if the operation is performed by others. Similarly, before setting off make sure that the doors are closed by checking the warning lights and also manually. The driver must be fully acquainted with the vehicle and its controls in order to handle and drive it correctly. Command of the vehicle can be acquired/improved by attending the driving courses held by **FERRARI** which we strongly recommend.

The use of terms from the motor sports world (such as F1, SPORT and RACE) is merely indicative of the vehicle's competition-derived technology and does not endorse inappropriate behaviour on the road which does not comply with Traffic Regulations.

While this vehicle has features that may be used on the track, it is a road-going vehicle and is not suitable for continuous use on the track.

Most accidents are caused by distraction. The driver must use any on-board information, communication and entertainment systems responsibly, especially when the vehicle is in motion.

Examples of information, communication and entertainment systems are the following: satellite navigation systems, traffic information systems (e.g. ITT), media players (e.g. iPod), telephones with Bluetooth connectivity, etc. (whether merely audio-based or with display).

It is important to bear in mind that on-board systems may be distracting when driving since they may take a driver's attention away from the road for several seconds. Aftermarket video entertainment systems for the passenger (e.g. TV) must be installed where they cannot distract the driver while the vehicle is in motion. While the vehicle is in motion, the attention required to use on-board systems must never exceed the high level of attention required to drive safely in accordance with the Traffic Regulations.

Therefore, these systems may only be used (separately or in combination with others) by the driver:

- in complete safety (stopping the vehicle before use if necessary). Operations that are not involved with driving (e.g. changing dashboard functions), must be performed in maximum safety when the vehicle is stationary;
- putting road safety first; for example, under conditions of poor or limited visibility, looking at a display with active programmes can be distracting even if you take your eye off the road only for a split second;



- ensuring, if the previous vehicle owner has installed systems on the vehicle that are NOT APPROVED by **FERRARI** (car tuning), that they are fully compatible with the original vehicle equipment.

If the vehicle owner has installed one or more new systems, either fixed or removable, on the vehicle, make sure that these

- have the necessary certification;
- are fully compatible with the original vehicle equipment (i.e. they do not interfere with it);
- are fitted by skilled staff.

The **FERRARI TECHNICAL SERVICE DEPARTMENT** and **FERRARI DEALERS** and **AUTHORISED SERVICE CENTRES** can provide all the information needed to ensure that they are compatible.

Strict priority criteria must be observed when driving a vehicle: you must not therefore take your attention and eye off the road.

In some countries, the use of entertainment/information systems is prohibited on vehicles when driving.

The driver is responsible for use of these entertainment/information systems with video screens if they are prohibited in the country where the vehicle will be driven.

These considerations are not exhaustive, but only refer to a number of general issues that will be specifically dealt with in this Owner's Manual.



Introduction

The aim of this Owner's Manual is to help you get the best value from your vehicle and to provide information on routine maintenance: we advise you to read it carefully before setting out. The Owner's Manual should be considered an integral part of the vehicle and must therefore always be kept on board.

Using the vehicle in a way that does NOT comply with the Owner's Manual not only exonerates **FERRARI** of any responsibility but also puts the person at great risk.

Updating

The high quality level of the vehicle is subject to constant technological improvements. Therefore, there may be differences between this manual and your vehicle.

The **FERRARI SALES AND SERVICE NETWORK** will provide you with all the information on any updates.

All specifications and illustrations contained in this manual are accurate as of the date of printing.

Spare parts

When replacing parts or topping up with lubricants and fluids, we recommend that you use original spare parts and lubricants and fluids recommended by **FERRARI**.

Warranty Booklet

Each new vehicle comes equipped with a "Warranty Booklet". This contains the vehicle's warranty validity conditions.

This warranty does not affect the buyer's statutory rights as a consumer, which derive from binding legal norms in his or her favour, in the various states or countries or from European Union regulations, towards the Dealer.

The Warranty Booklet also contains the routine maintenance indicated in the "Maintenance Schedule".



Service

The information in this manual is necessary for the use and proper care of the vehicle. In addition, Customers will get maximum satisfaction and results from the vehicle if they carefully follow the instructions contained in it.

We recommend that you have all the checks and services performed at **FERRARI AUTHORISED WORKSHOPS** since they have highly skilled staff and the necessary equipment.

In the case of erroneous maintenance or repairs (that do not conform to the technical repair standards and procedures adopted by **FERRARI**), undertaken by independent repair centres, particularly if concerning safety systems or safety, **FERRARI** may decide to not carry out further repairs on the vehicle, unless the vehicle is restored so that it conforms to original parameters.

The Customer Care Service, available at the numbers indicated in the “Reference Guide” booklet enclosed with the vehicle documents, can provide information on the location of the **FERRARI DEALERS** and **AUTHORISED SERVICE CENTRES**.

The **FERRARI TECHNICAL SERVICE DEPARTMENT** is at your complete disposal for any information and advice. If you have any doubts about the information provided in this manual or how to use or operate the vehicle, please contact the **FERRARI SERVICE NETWORK**.

Consulting the manual

To facilitate reading the manual, the topics have been divided into sections and chapters.

1. *General*

Provides general information about your vehicle.

2. *Safety*

Describes the main safety systems in the vehicle.

3. *About your Vehicle*

Provides all necessary information for use of the vehicle.

4. *Advice for Emergency Situations*

Provides useful advice for solving problems that may occur.

5. *Care of the vehicle*

Provides advice for cleaning, care and routine maintenance of your vehicle.

6. *Glossary*

Explains the main technical concepts.

7. *Table of Contents*

Allows you to quickly identify and locate the information required.



Within the various sections, special attention must be paid to the parts marked as follows:

Warning



Extreme caution required: failure to comply with the instructions could constitute a serious risk to personal safety and vehicle protection!

Important note



Important note: a note containing instructions or information.

Environment



Warning for environmental protection: useful advice for protection of the environment.

Abbreviations/Acronyms

Some descriptions and terms with particular meanings are found in this manual in an abbreviated form:

AC	AIR CONDITIONING
ABS	ANTI-LOCK BRAKING SYSTEM
ASR	ANTI-SKID REGULATION during acceleration
DCT	DUAL CLUTCH TRANSMISSION
EBD	ELECTRONIC BRAKE-FORCE DISTRIBUTION
ECU	ELECTRONIC CONTROL UNIT
ESC	ELECTRONIC STABILITY CONTROL
F1-Trac	Traction control derived from the technologies used in the racing sector



Environmental protection

Environment



The following chapter contains useful advice for environmental protection.

FERRARI has designed and constructed a vehicle using technologies, materials and devices capable of reducing the harmful impact on the environment to a minimum.

If you use your vehicle with respect for the environment, you too will contribute towards environmental protection.

Fuel consumption as well as engine, gearbox, brakes and tyres wear mainly depend on two factors:

- use of the vehicle;
- driving style.

Both factors are influenced by the driver.

Use of the vehicle

- Avoid using the vehicle for short trips.
- Check that the tyre pressure is correct.
- Check the fuel consumption.
- Proper periodic maintenance will contribute to preserving your vehicle in full working order and to protecting the environment. We therefore advise you to respect the service due dates indicated in the "Maintenance Schedule".

Driving style

- Do not accelerate during the starting procedure.
- Do not warm up the engine when the vehicle is stationary.
- Drive carefully and keep a safety distance that corresponds to the driving speed.
- Avoid sudden and frequent acceleration or braking.
- Turn off the engine if the vehicle is kept stationary for long periods of time.
- Shift gears using only 2/3 of the speed permitted for each gear.
- Use the air conditioning in moderation.

Important note



The vehicle is equipped with exhaust gas control and monitoring systems which must always be kept in perfect working order and controlled regularly.



Directive for the treatment of end-of-life vehicles (EU only)

For many years, FERRARI has been globally committed to respecting and protecting the environment by constantly improving its manufacturing processes and developing increasingly eco-compatible products.

Regulations for the treatment of end-of-life vehicles, implemented in response to the terms of EU Directive 2000/53, require that producers (manufacturers and official importers) collect all the vehicles introduced on the market by the producers themselves at the end of their life cycle, and ensure that these vehicles are processed in an environmentally compatible manner.

To hand over your FERRARI at the end of its life cycle for treatment at no additional cost (excluding deregistration and transport), take your vehicle to the nearest FERRARI dealer, which will, at its own expense, transport the vehicle to one of the authorised collection and demolition centres, which have been selected to ensure that all processes for the collection, treatment and recovery of recyclable materials are carried out in an environmentally compatible manner.

For further information, visit the website www.ferrari.com.

When handing over a FERRARI vehicle at the end of its life cycle:

- the vehicle must be complete, containing all the essential elements such as the engine, transmission, bodywork, ECUs and catalytic converters;
- the vehicle must not contain any additional refuse.

FERRARI is committed to offering its clients a geographically extensive and, as a result, better service, and thanks you for your cooperation in this environmental challenge.

Vehicle keys	14
Key and receiver homologation certificates.....	15
Alarm system.....	18
Duplicating the keys	19
Replacing remote control batteries	20
Electronic alarm	20
Identification and homologation plates and labels..	24
Dimensions and weights	30
Main engine specifications	31
Consumption and emissions	31
Performance.....	31
Wheel rims and tyres.....	32
Refilling.....	38



1



GENERAL





Vehicle keys

The vehicle is delivered with two identical keys that can be used for:

- mechanically opening/closing doors;
- remotely opening/closing doors;
- keyless ignition of the vehicle (see page 135);
- activating/deactivating the alarm system;
- opening the luggage compartment lid;
- activating the “welcome light”.

Important note



If the keys are lost or stolen, you can request a duplicate from the FERRARI SERVICE NETWORK (see section “Duplicating the keys” on page 19).



Important note



To guarantee optimum ignition and driving, place the key inside the passenger compartment near the driving area.

Key codes

A **CODE CARD** is supplied together with the keys, indicating the following:

- the electronic code;
- the mechanical code for the keys, to be given to the FERRARI SERVICE NETWORK if you request duplicates of the keys.

Warning



The code numbers on the **CODE CARD** must always be kept in a safe and protected place, not accessible to others.





Important note



In the event of a change of ownership, it is essential that the new vehicle owner is provided with all the keys and with the **CODE CARD**.

Vehicle transmitter and key homologation certificates

Hereby, Continental, declares that this vehicle key is in compliance with the essential requirements and other relevant Provisions of the Directive 1999/5/EC.

		Interior	
Continental Automotive GmbH, Siemensstraße 12, 93055 Regensburg, Germany		Sven Kubel 1 BS RD CRRF WM Phone: +49-941-790-90292 Fax: +49-941-79099-90292 Sven.Kubel@continental-corporation.com	
Date	Your message dated	Our reference	Your reference
08.05.2015			
Declaration of Conformity in accordance with Directive 1999/5/EC (R&TTE Directive)			
Manufacturer:	Continental Automotive GmbH		
Address:	Siemensstraße 12 D-93055 Regensburg Germany		
Product type designation:	A2C978068		
Intended use:	Radio frequency transmitter used in vehicle locking/unlocking systems		
The product mentioned above complies with the essential requirements and other relevant provisions of Directive 1999/5/EC, when used for its intended purpose.			
Health and safety pursuant to Art. 3(1)(a):	<i>Applied standard(s):</i> IEC 60950-1:2005 + CORR:2006 + A1:2009 + A2:2013 EN 60950-1:2006 + A11:2009 + A1:2010 + A12:2011 + AC:2011 + A2:2013 EN 60950-1:2007 + A11:2009 + CORR:2007 + A1:2011 + A12:2011 + AC:2012 + A2:2014		
Electromagnetic compatibility pursuant to Art. 3(1)(b):	<i>Applied standard(s):</i> EN 301 489-1: V1.9.2 (2011-09) EN 301 489-3: V1.6.1 (2013-08)		
Efficient use of spectrum pursuant to Art. 3(2):	<i>Applied standard(s):</i> EN 300 220-1: V2.4.1 (2012-05) EN 300 220-2: V2.4.1 (2012-05) EN 300 330-1: V1.7.1 (2010-02) EN 300 330-2: V1.5.1 (2010-02)		
The following marking applies to the above mentioned product:			
Continental Automotive GmbH Regensburg, 08.05.2015			
 Andreas Wolf Executive Vice President Body & Security	 Norbert Müller Director RD Body & Security		
1/1			

1



Continental Interior

Continental Automotive GmbH – P.O. Box 10 09 43 – D-93029 Regensburg

Dagmar Kolar
RF Homologation / QL RBG 43
Phone +49 941 790-6599
Fax +49 941 790-62786
dagmar.kolar@continental-corporation.com

Date: May 14, 2014 Your message dated: Our reference: Your reference:

Declaration of Conformity in accordance with Directive 1999/5/EC (R&TTE Directive)

Manufacturer: Continental Automotive GmbH
Address: Siemensstrasse 12
D-93055 Regensburg
Germany

Product type designation: S180222004 and A2C91227100
Intended use: Keyless entry and immobilizer system

The product mentioned above complies with the essential requirements and other relevant provisions of Directive 1999/5/EC, when used for its intended purpose:

Health and safety pursuant to Art. 3(1)(a):
Applied standard(s): EN 60950-1:2006 + A11:2009 + A1:2010 + A12:2011 EN 62369-1:2009

Electromagnetic compatibility pursuant to Art. 3(1)(b):
Applied standard(s): EN 301 489-1 V1.9.2 (2011-09) EN 301 489-3 V1.4.1 (2002-08)

Efficient use of spectrum pursuant to Art. 3(2):
Applied standard(s): EN 300 330-1 V1.7.1 (2010-02) EN 300 330-2 V1.5.1 (2010-02)

The following marking applies to the above mentioned product:

Continental Automotive GmbH
Regensburg, 2014-05-14

CE

Andreas Wolf
Executive Vice President
Body & Security

Norbert Müller
Director Research & Development
Body & Security

1/1

Continental Interior

Continental Automotive GmbH, Siemensstraße 12, 93055 Regensburg, Germany

Sven Kubell
IBS RD CFRF WM
Phone: +49-941-790-90292
Fax: +49-941-79099-90292
Sven.Kubell@continental-corporation.com

Date: 17.03.2015 Your message dated: Our reference: Your reference:

Declaration of Conformity

We, the undersigned, declare that

The Keyless Entry and Immobilizer Electronic Control Unit (ECU) S180243200 uses the same schematic, assembly and PCB as the ECU S180222004.

They only differ in:

The additional population of the ESCL (Electronic Steering Column Lock) line as KL15 output, which allows to provide 12 V to another ECU.

These modifications do not influence the RF characteristics of the radio transmitter and radio receiver.

Yours truly,

Regensburg, 17.03.2015

Andreas Wolf
Executive Vice President
Body & Security

Norbert Müller
Director RD
Body & Security

1/1



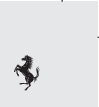

Continental 

Continental Automotive GmbH – Postfach 100 963 – 93069 Regensburg

Josef Lohr
 IBS PG3 CFRF WM
 Phone +49 (941) 790-8942
 Fax +49 (941) 790-998942
 josef.lohr@continental-corporation.com

Date	Your message dated	Our Reference	Your reference
May 10, 2010			

Declaration of Conformity in accordance with Directive 1999/5/EC (R&TTE Directive)

Manufacturer: Continental Automotive GmbH
 Address: Siemensstrasse 12
 D-93055 Regensburg
 Germany

Product type designation: 5WK50257, 5WK50254, 5WK50252, 5WK50250, 5WK50248,
 40398036, 40406557, 40398279

Intended use: Radio frequency receiver used in vehicle locking/unlocking systems

The product mentioned above complies with the essential requirements and other relevant provisions of Directive 1999/5/EC, when used for its intended purpose.

Health and safety pursuant to §3.1.a:	<i>Applied standard(s):</i> EN 60950-1: 2006
Electromagnetic compatibility pursuant to § 3.1.b:	<i>Applied standard(s):</i> EN 301 489 -1: V1.8.1 (2008-04) EN 301 489 -3: V1.4.1 (2002-08)
Efficient use of spectrum pursuant to § 3.2:	<i>Applied standard(s):</i> EN 300 220 -1: V2.1.1 (2006-04) EN 300 220 -2: V2.1.2 (2007-06)

The following marking applies to the above mentioned product:

CE

Continental Automotive GmbH
 Regensburg, 2010-05-10

 Andreas Wolf

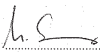
 Dr. Ulrich Schrey



Alarm system

The FERRARI CODE system

The vehicle is equipped with an electronic immobiliser system (FERRARI CODE) which is automatically activated when the engine is switched off. The keys are equipped with an electronic device which transmits a coded signal to the FERRARI CODE ECU. Once this ECU has recognised the signal, it allows the engine to start.

Operation

Each time the engine is switched off, the protection system activates the immobiliser.

- When starting the engine, press the **ENGINE START/STOP** button on the steering wheel:

- 1) If the key is recognised, the **CODE** warning light **A** on the instrument panel turns off, whereas the **EOBD** warning light **B** only goes off when the engine has started once the **ECU** has completed its diagnostic cycle; in these conditions, the protection system has recognised the key code and deactivated the immobiliser.
- 2) If the **CODE** warning light **A** stays on, it means that the code has not been recognised. If this occurs, we recommend switching the instrument panel off and switching it back on again by pressing the **ENGINE START/STOP** button on the steering wheel; if the immobiliser device remains active, try with the other key provided.

Important note



If you still cannot restart the engine, contact the **FERRARI SERVICE NETWORK**.

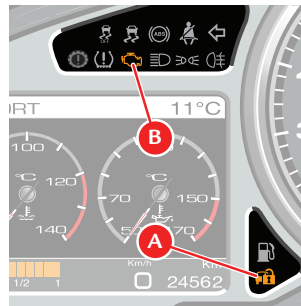



- While driving with the engine running:

- 1) If the **CODE** warning light **A** turns on, it means that the system is performing a self-diagnostic cycle. At the first opportunity, you can stop and test the system: when you switch off the engine and switch it on again by pressing the **ENGINE START/STOP** button, the **CODE** warning light **A** comes on and should go out within one second.
If the warning light stays on, repeat the procedure described previously after switching the instrument panel off for more than 30 seconds.

Important note



If the problem persists, please contact the **FERRARI SERVICE NETWORK**.

- 2) If the **CODE** warning light **A** flashes, it means that the vehicle is not protected by the immobiliser.

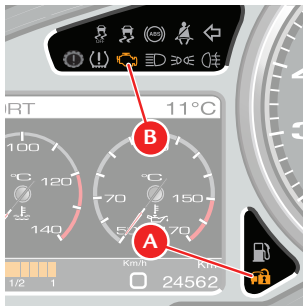

Important note



Contact the **FERRARI SERVICE NETWORK** immediately to have all the keys stored in the system memory.

1

Important note



Each key provided has its own specific code, which must be stored in the memory of the system control unit.

Duplicating the keys

If you request additional keys, provided that the conditions to satisfy your request are met, remember that the codes must be stored (up to a maximum of 6 keys) on all the keys. Contact the **FERRARI SERVICE NETWORK** directly and bring the following with you:

- all the keys in your possession;
- the **CODE CARD** for the **FERRARI CODE** system;
- a personal identity document;
- the documents proving ownership of the vehicle;
- a report of loss of keys made to the relevant authorities.

The codes for the keys that are not available when the new memorisation procedure is performed will be deleted from the memory to prevent any lost or stolen keys being used to start the vehicle.



Replacing remote control batteries

If the key battery is insufficiently charged or only charged enough to guarantee correct operating, the vehicle system informs the driver via a message on the left TFT display (see page 84).

Replace the remote control batteries as follows:

- remove the metal bar **L**;
- open the key cover **C** using a small screwdriver at the position indicated by the arrow;
- remove the battery **E**;
- insert a new battery of the same type, observing the indicated polarity;
- close the key cover **C**;
- re-insert the metal bar **L**.

Important note



Do not use sharp tools to remove the cover and be careful to avoid damaging the remote control.

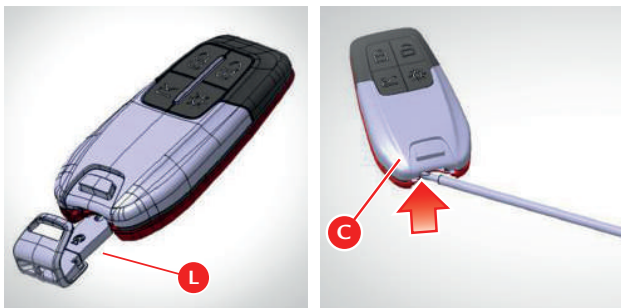

Electronic alarm

The electronic alarm system performs the following functions:

- remote control for central door locking/unlocking;
- perimeter surveillance, detecting if doors and lids are open;
- motion surveillance, detecting intrusion in the passenger compartment;
- vehicle movement surveillance.

Activation

To activate the alarm system, press button **F** on the ignition key:

- the turn indicators flash once;
- the system “beeps”;
- the red LED on the dashboard flashes;
- the central door locking system of the vehicle is activated and the doors are locked.

The system activates after approximately 25 seconds.

When the electronic alarm is activated, the user may request opening of the luggage compartment; in this case, the motion and anti-lift sensors are temporarily deactivated.

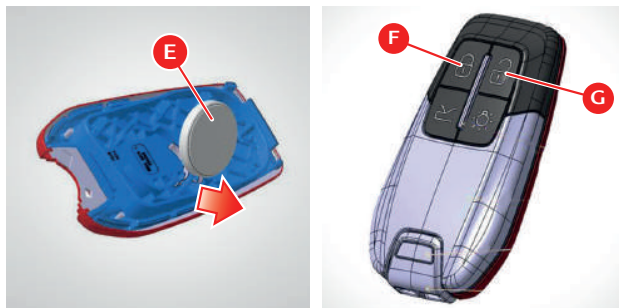



If the luggage compartment is then closed, the sensors will be reactivated.

If the turn indicators and the red LED on the dashboard flash 9 times when you activate the alarm system, it means that one of the doors or the front/rear lid is open or not closed properly and is therefore not protected by the perimeter surveillance. If this is the case, check that the doors and front/rear lids are closed properly and close any door or lid that is open without deactivating the alarm system: the turn indicators will flash once to indicate that the door and front/rear lids are now closed properly and protected by the perimeter surveillance.

Warning



If the turn indicators and the red LED on the dashboard flash 9 times when the alarm system is activated with the doors and front and rear lids properly closed, it means that the self-diagnostic feature has detected a malfunction in the system. Contact the FERRARI SERVICE NETWORK to have the system checked.

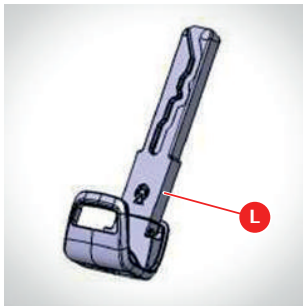

Deactivation

To deactivate the alarm system, press button **G** on the ignition key:

- the turn indicators flash twice;
- the system beeps twice;
- the red LED on the dashboard goes off;
- the dome lights come on;
- the central door locking system of the vehicle is deactivated and the doors are unlocked.

Pressing button **G** twice unlocks the doors and also turns on the low beams for 30 seconds. The alarm system is off and you can now get into the vehicle and start the engine.

1

Important note



To enter the vehicle if the remote control battery is flat, remove the metal bar **L** and insert the key into one of the two door locks and turn it to release the lock; the alarm siren will activate. Start the vehicle following the emergency procedures; the alarm siren will deactivate (see page 204).



Deactivating the anti-lift alarm

Press button **H** on the roof panel to deactivate the anti-lift alarm system. When this function is deactivated, the indicator light on the button will flash for about 3 seconds and will then turn off.

Alarm memory

If, when the vehicle is started, the **CODE** symbol (see page 104) appears on the left TFT display for 10 seconds after the system diagnosis cycle, together with the message “Break-in attempted”, this means there has been an attempt to break into the car, causing the alarm to activate.

In this case, the system will indicate the reason for the alarm activation according to the following priority:

- **LED off twice:** anti-lift sensor alarm.
- **LED off three times:** door alarm.
- **LED off four times:** luggage compartment lid alarm.
- **LED off five times:** ignition key alarm.

When the engine is switched on, the alarm system memory is reset.





Homologation

The installed electronic alarm system complies with EU (European Union) regulations on electromagnetic compatibility and it is marked accordingly.

For those markets that require the transmitter and/or receiver marking, the homologation number is found on the component.

Satellite alarm system (optional)

In some markets, the vehicle can be equipped, on request, with a satellite alarm system. If the vehicle is equipped with a satellite alarm system, please refer to the "Nav Trak Satellite Alarm System Quick Reference" booklet enclosed with the vehicle documents, for further information.



Identification and homologation plates and labels

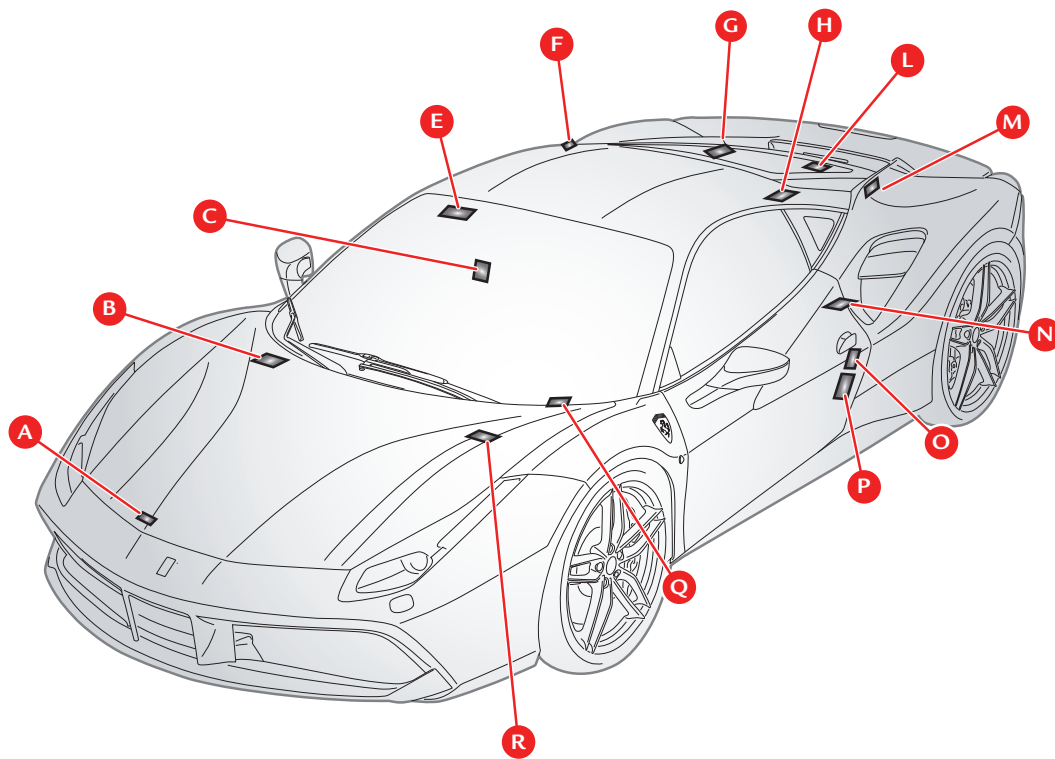



Ref.	Label/plate	Position
A	Low-beam homologation	Luggage compartment lid
B	ECE homologation	Luggage compartment lid
C	Vehicle identification	Rear passenger-side door jamb
E	Passenger airbag warning	Passenger-side sun visor
F	Unleaded fuel	Fuel filler flap
G	Radiator with antifreeze	RH engine compartment cosmetic shield
H	Engine type and number	Crankcase
L	Assembly number	Engine compartment
M	Engine and gearbox oil label	LH engine compartment cosmetic shield
N	Gearbox type and number	Gearbox housing
O	Tyre pressure and type	Driver-side door
P	TPMS present warning	Driver-side door
Q	Chassis number	Windscreen
R	Original paintwork	Luggage compartment lid



A Low-beam homologation

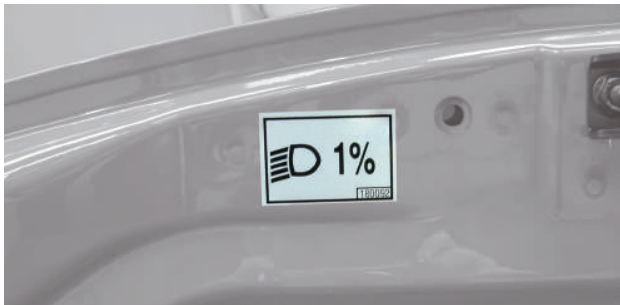

C Vehicle identification



B ECE homologation

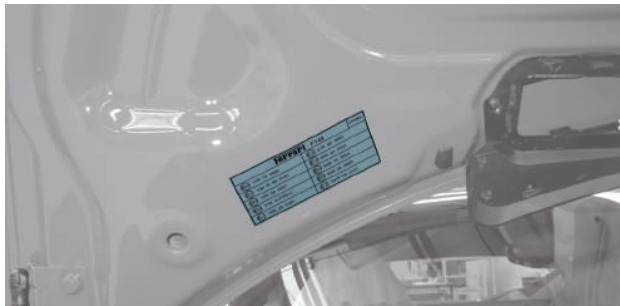



E Passenger airbag warning



G Radiator with antifreeze



1

F Unleaded fuel



H Engine type and number

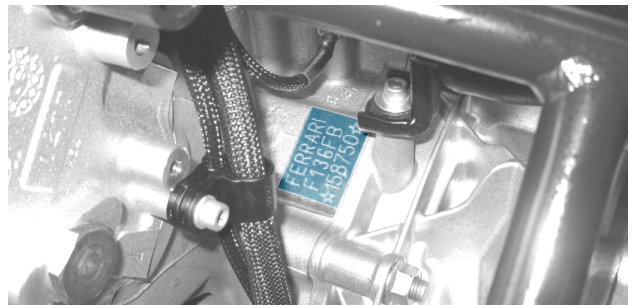



L Assembly number



N Gearbox type and number



M Engine and gearbox oil label



O Tyre pressure and type

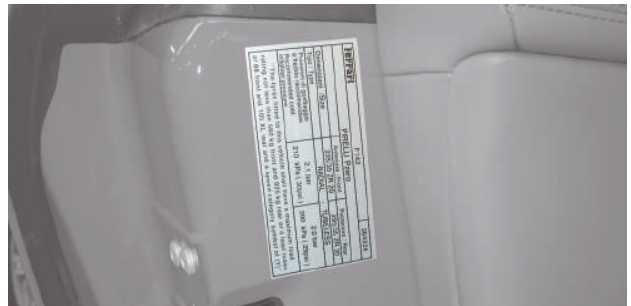



P TPMS present warning



R Original paintwork



1

Q Chassis number





Dimensions and weights

Wheelbase	2650 mm
Max. length	4568 mm
Max. width	2261 mm
Max. height	1203 mm
Front track	1679 mm
Rear track	1647 mm
Front overhang	1143 mm
Rear overhang	775 mm
Dry weight	1370 kg *
Kerb weight	1475 kg *

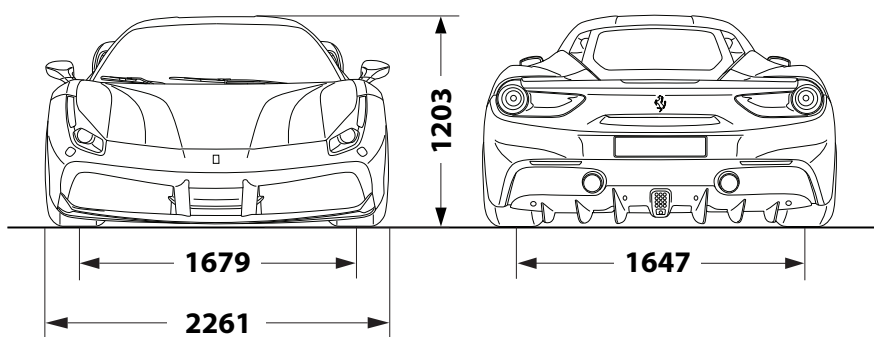

* considering the most favourable Optional combination

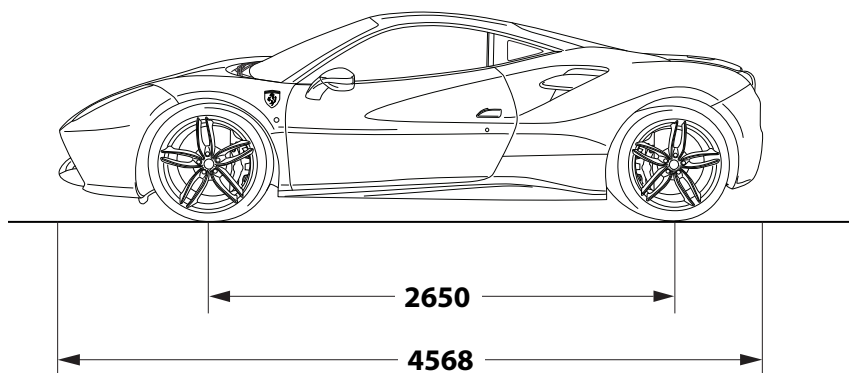



Main engine specifications

Type	F 154 CB
Number of cylinders	8
Cylinder sequence	V 90°
Cylinder bore	86.5 mm
Piston stroke	83 mm
Total displacement	3902 cm ³
Compression ratio	9.6:1
Max. RPM (with limiting device)	8000 RPM
Max. power	493 kW (670 hp)
Corresponding RPM	8000 RPM
Max. torque	760 Nm*
Corresponding RPM	3000 RPM

*only in 7th gear

Consumption and CO₂ emissions

	Standard version		With HELE system	
	l/100 km	g/km	l/100 km	g/km
City cycle	18.4	419	16.6	377
Motorway	8.6	196	8.4	193
Combined cycle	12.1	277	11.4	260

Transmission ratios

Gearbox ratios	Differential/bevel gear pair ratio
1 = 3.334	
2 = 2.285	
3 = 1.728	4.375
4 = 1.369	
5 = 1.115	
6 = 0.875	
7 = 0.642	
R = 2.979	

Performance

0 - 100 km/h	0 - 200 km/h	Max. speed
3.0 s	8.3 s	> 330 km/h (202 mph)

Electrical system

Supply voltage	Alternator
12 V	Nippondenso 200 A SC5
Battery*	Starter motor
Fiamm 12V - 70 A/h L3 VRLA 760A EN	Bosch

1



Wheel rims and tyres

Standard

Front	Rear	Space saver spare wheel
9" J x 20" ET 44.7	11" J x 20" ET 38.5	4.5" J x 20"

Explanation of wheel rim codes

Example: 9" J x 20" ET 44.7

9" = Rim width in inches









J = Shape of rim edge (side projection where tyre bead rests)

20" = Rim diameter in inches

ET 44.7 = Offset (distance, in mm, between the centreline of the rim and inner rim surface)



1

FERRARI-approved tyres			Inflation pressure (cold)	 *	 *	 *
Michelin Pilot Super Sport	Front	245/35 ZR20	2.10 bar	E	B	71 dB
	Rear	305/30 ZR20	2.00 bar	E	A	73 dB
Optional tyres			Inflation pressure (cold)	 *	 *	 *
Bridgestone Potenza S007	Front	245/35 ZR20	2.10 bar	E	B	73 dB
	Rear	305/30 ZR20	2.10 bar	F	E	73 dB
Pirelli PZero	Front	245/35 ZR20	2.10 bar	E	A	73 dB
	Rear	305/30 ZR20	2.00 bar	E	A	72 dB
Vredestein space saver spare wheel		145/60 R20	4.20 bar	-	-	-
Winter tyres			Inflation pressure (cold)	 *	 *	 *
Pirelli Winter Sottozero	Front	235/35 R20 M+S	2.10 bar	E	C	72 dB
	Rear	285/35 R20 M+S	2.00 bar	C	C	73 dB

*: Regulation no. 1222/2009/EC (see page 36)

Warning



The maximum speed allowed with winter tyres is 240 km/h.



Explanation of codes and wording on tyre side walls

1) Tyre size and characteristics

Example: **245/35 ZR 20 (105Y)**

245 = Nominal width (distance in mm from side to side)

35 = Height/width ratio as a percentage

ZR = Radial tyre that can withstand speeds above 240 km/h.

Combined with the specific load and speed code (in brackets), this indicates a tyre that can withstand speeds above 300 km/h.

20 = Rim diameter in inches

105 = Load index: numerical code associated with the maximum load permissible on the tyre at a given pressure, at the speed corresponding to the relative index. The maximum load permissible is indicated in kg and pounds in the wording (3).

Y = Speed index

This indicates the maximum speed at which the tyre can withstand the load indicated in the load index.

Speed indexes (ECE-UN 30) are shown in the table below:

Speed Index	Maximum speed (km/h)
M	130
N	140
P	150
Q	160
R	170
S	180
T	190
U	200
H	210
V	240
W	270
Y	300
ZR (... Y)	> 300

The speed index Y, shown in brackets and associated with the abbreviation ZR, indicates a tyre that can withstand speeds above 300 km/h.

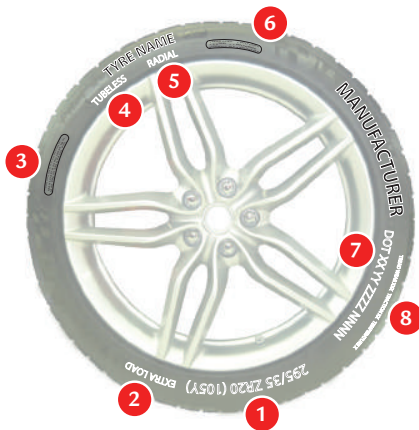



- 2) **EXTRA LOAD:** tyre with a high load capacity
- 3) Maximum load permissible, indicated in kg and pounds, and maximum inflation pressure permissible, indicated in kPa and psi.
- 4) **TUBELESS:** the tyre has no air chamber
- 5) **RADIAL:** radial tyre
- 6) Details of materials used to construct the tread and tyre side wall.
- 7) **DOT XX YY ZZ NNNN**

DOT (Department Of Transportation) specifications: marking relative to US regulations, with information on the manufacturer, production site, tyre type and size. The last four digits, in a box, indicate the date of manufacture: 1011 means that the tyre was manufactured in the 10th week of 2011.

Warning



The **FERRARI SERVICE NETWORK** is suitably equipped to replace tyres and to determine whether a tyre is safe for use.
Only have the tyres replaced by the **FERRARI SERVICE NETWORK** which has the necessary equipment since careless handling may damage the sensor inside the wheel rim.

- 8) **Uniform Tire Quality Grading:** standard, defined by the US Department of Transportation, that classifies tyre performance in terms of treadwear, traction and temperature resistance.

For further information on tyres, see page 247.

1



Regulation no. 1222/2009/EC (applies to EU countries only)

Regulation no. 1222/2009/EC states that all tyres sold in EU countries produced after 1 July 2012 must bear a label (as shown in the bottom right) containing important information on performance.

The aim of the regulation is to provide consumers with more information on safety (wet grip) and environmental (rolling resistance and external rolling noise) issues in order to promote the use of safer, quieter and more efficient tyres.

The label provides the following information:

Fuel consumption

The fuel consumption of a vehicle is influenced by the tyre rolling resistance. There is a scale with 7 levels, from A to G, on the left of the label where “A” indicates the best tyre class for reducing fuel consumption with lower rolling resistance.

Wet grip

On the right of the label, there is a scale for tyre performance when braking on wet roads. Measurements are taken under test conditions defined in the European Regulation. The scale has 7 levels, from A to G, where “A” indicates the maximum wet grip.

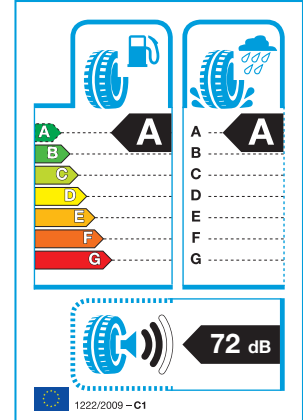



1

External rolling noise

The bottom of the label indicates the external noise level of the tyre. The external noise level is measured in decibels (dB) and is divided into 3 categories based on the new, stricter European levels of external tyre noise which will be introduced by 2016.

- 1 black sound wave: 3 dB below future European limit.
- 2 black sound waves: complies with future European limit.
- 3 black sound waves: complies with current European limit.



Refilling

<i>Parts to be refilled</i>		<i>Quantity</i>	<i>Fluid specifications for correct operating of vehicle:</i>	<i>Recommended by FERRARI:</i>	<i>Ref. page</i>
Engine	Total system capacity	10.5 l	Engine oil SAE ¹⁾ 5W-40	SHELL HELIX ULTRA SAE 5W-40	242
	Oil level between Min. and Max.	1.5 l	API ²⁾ SN/CF		
	Oil consumption	1.0 - 2.0 l/ 1,000 km	ACEA ³⁾ A3/B4		
Gearbox and differential		3.4 l	Transmission fluid SAE ¹⁾ 75W-90	75W-90 SHELL SPIRAX S5 ATE	243
Clutch system and hydraulic controls		7.55 l	DCT-F3 or equivalent	SHELL DCT-F3	
Braking system		1.0 l	DOT4 ⁴⁾	PETRONAS TUTELA TOP5FF or SHELL BRAKE AND CLUTCH DOT4 <i>Ultra</i>	245
Cooling circuit		19.7 l	Prediluted antifreeze/ coolant	CARIX Premium Longlife mixed with 50% demineralised water	244
Hydraulic power steering system		1.8 l	CHF 11S or equivalent	PENTOSIN CHF 11S	244
Fuel tank		78 l	Unleaded petrol (at least 95 R.O.N. ⁵⁾)	Unleaded petrol (at least 98 R.O.N. ⁵⁾)	78
Reserve		13 l			
Air conditioning and heating system					
Compressor		165 cc	PAG ISO 46		
Coolant		650 ± 30 g	HFO 1234 YF	HFO 1234 YF	
Windscreen washer/headlight washer fluid tank		5 l	Mixture of demineralised water and glass cleaner		246



- 1) **SAE - Viscosity grade:** example SAE 5W - 40.
5W = indicates the viscosity grade at low temperatures (winter).
40 = indicates the viscosity grade at high temperatures.
- 2) **API - American Petroleum Institute:** e.g. SN/CF.
SN = the first letter indicates that an engine oil is suitable for petrol engines, the second letter indicates the oil quality based on API tables.
CF = the first letter indicates that an engine oil is suitable for diesel engines, the second letter indicates the oil quality based on API tables.
- 3) **ACEA - European Automobile Manufacturers Association:** e.g. A3/B4.
A3 = indicates a high performance engine oil suitable for petrol engines.
B4 = indicates a high performance engine oil suitable for diesel engines.
- 4) **DOT - Brake fluid classification:** indicates the chemical/physical characteristics of the brake fluid in question.
- 5) **R.O.N. - Octane rating:** indicates the knock resistance of a fuel.

Important note



For optimal engine performance and efficiency, FERRARI recommends using unleaded petrol with an octane rating (R.O.N.⁵⁾ of 98 or higher.

Warning



Only refuel with unleaded petrol (at least 95 R.O.N.⁵). The use of unleaded petrol with a R.O.N.⁵ below 95 can cause malfunctioning and is not recommended. **Never** put leaded petrol in the fuel tank, not even in emergencies.

Important note



This vehicle is suitable for use with unleaded fuel with a maximum of 10% ethanol (E10).

Warning



The use of fuels with 10% to 25% ethanol can lead to malfunctioning.
The use of fuels with over 25% ethanol can cause permanent damage to the engine fuel system.

1

Passive safety.....	44
Active safety	45
Seat belts	46
How to fasten seat belts.....	48
Pretensioners.....	50
Auxiliary Occupant Protection Systems.....	52
Front airbags.....	53
Child restraint systems.....	57
Side airbags.....	58
Fuel inertia switch.....	60
ABS and EBD	61
Stability and Traction Control	62
Electric parking brake	64
TPMS system.....	65



SAFETY





FERRARI has designed and built a high performance vehicle. In order to take advantage of the safety systems described below, it is essential to comply with the indicated regulations.

Special recommendations

This vehicle has been built to comply with homologation regulations that also concern safety and environmental protection.

It has high technological standards which must always be accompanied by careful and cautious driving.

Particular attention must be paid to:

- Overheated components. High temperatures develop in the engine compartment near the exhaust system. Do not park the vehicle on paper, grass, dry leaves or other flammable materials. They could catch fire if they come into contact with hot parts of the exhaust system. Do not fit other heat shields or remove those fitted on the exhaust system. Do not let flammable substances come into contact with the exhaust system.
- Moving parts of the vehicle such as belts, fans, etc. They must always be adequately protected. Do not remove the guards or operate on the moving parts without taking due precautions.
- Installations under pressure such as braking system, air conditioning system, cooling system and lubrication system may create pressures inside them. Do not perform any operation which may cause gas or liquids to spill out with the risk of injury to persons and damage to things.

Emissions

Warning



- The exhaust gas generated by the running engine may be hazardous, especially when in closed spaces. As well as consuming oxygen, the engine discharges carbon dioxide, carbon oxide and other toxic gases.
- Fuel is highly inflammable and emits vapours which may be noxious if inhaled.
Do not use naked flames or create sparks near the open fuel tank or in any other condition where fuel comes into contact with air.

Lubricants

Warning



- The oils used may also be flammable: take the same precautions as those adopted for fuel.

Flammable fluids

Warning



- The fluid in the battery is poisonous and corrosive. Do not let it spill out and come into contact with the skin, eyes or objects. Do not use naked flames or create sparks near the battery.



Fuel inertia switch

- See page 60.

Warning



Seat belts must be worn at all times and must be properly fastened and adjusted!

Correct use of the seat belts can significantly reduce the risk and severity of injury if an accident occurs or if the vehicle overturns.

Warning



For an effective restraining action, the seat belt must be fastened correctly with the seat backrest in the upright position.

The seat belt is fastened correctly when the upper part of the belt crosses the centre of the shoulder (not the neck) and the abdominal section is fitted over the hips (not the abdomen).

Make sure that the belt is not twisted and that it passes closely over your body; if not, in the event of a head-on collision, it may move and cause injury to the abdomen.

Avoid wearing bulky clothing that may interfere with the proper operation of the seat belts.

Warning



Each seat belt has been designed to protect only one occupant. If more than one person uses the same seat belt, the risk of injury in the event of an accident is increased.

Do not sit babies, small children or other persons on your lap.

If there is a collision, the weight of an adult may cause the child to be crushed by the seat belt causing severe or even fatal injuries.

2



Passive safety

The passive safety system has been designed to reduce the risk and severity of injury if an accident occurs.

The vehicle is equipped with the following seat belts:

- 3-point driver's seat belt with pretensioner and load limiting device (see page 46);
- 3-point passenger seat belt with pretensioner and load limiting device (see page 46).

Warning



Auxiliary safety systems are not a substitute for seat belts. All occupants must always wear a seat belt. Correct use of the seat belts combined with use of the auxiliary safety systems provides optimal protection to the occupants in various types of collisions.

The vehicle also has the following auxiliary occupant protection system components (see also page 52 "Auxiliary driver and passenger protection systems"):

- front driver's airbag (for operating functions, see page 53);
- front passenger airbag (for operating functions, see page 53);
- driver's head protection side airbag (head bag) (for operating functions, see page 58);
- passenger head protection side airbag (head bag) (for operating functions see page 58);
- seats (see page 166);
- deformable body;

- occupant protection system ECU;
- ECU auxiliary sensors;
- instrument panel warning light (see page 104);
- inertia switch.

Warning



The protective action of the airbags is always integrated with the seat belts and the pretensioners. The compulsory use of the seat belt is provided by the national regulations (in Italy, for example, by the Codice della Strada, i.e. Traffic Regulations).

Deformable body

The deformable body absorbs shock and distributes it over the entire structure of the vehicle allowing progressive deceleration.

The passenger compartment structure, on the other hand, has been designed to provide maximum resistance without undergoing deformation in order to guarantee a protective survival cell for the occupants.



Active safety

The aim of the active safety system is to reduce the risk of accidents and injury severity.

The vehicle has been designed to provide a high level of safety for whoever uses it. The following systems are specific active safety components:

- braking system;
- air conditioning and heating system;
- external lights;
- buzzer and warning lights (flashing).

The braking system includes the mechanical brake system and the electronic stability and traction control system (ABS and EBD): this is designed to prevent the wheels from locking and to provide good handling and stability.

In some situations, fast acceleration is important to get out of dangerous situations. However, always use the accelerator with extreme caution. During acceleration of the driving wheels, the anti-skid system may help you in certain dangerous situations.

The air conditioning and heating system in the passenger compartment can add to driving comfort and keep you alert so that you can react quickly when necessary.

It is very important to be able to see the road clearly and be seen and external lights must be turned on when the conditions so require.



Seat belts

Statistics show that when used correctly, seat belts reduce the risk of injury in various types of crashes including the risk of ejection from the vehicle and impact with the interior of the vehicle.

If unfastened, the seat belts do not provide any type of protection. Before every trip, always make sure that all occupants are wearing their seat belts.

Warning



Seat belts must be worn at all times and must be properly fastened and adjusted!

Correct use of the seat belts can reduce the risk of serious injury in the event of an accident or if the vehicle overturns.

Warning



For an effective restraining action, the seat belt must be fastened correctly with the seat backrest in the upright position.

The seat belt is fastened correctly when the upper part of the belt crosses the centre of the shoulder (not the neck) and the abdominal section is fitted over the hips (not the abdomen).

Make sure it is not twisted and that it passes closely over your body; if not, in the event of a head-on collision, it may move and cause injury to the abdomen.

Avoid wearing bulky clothing that may interfere with the proper operation of the seat belts.

The seat belts have a lap-shoulder belt with an automatic emergency-locking retractor and are fitted with a pyrotechnic-powered pretensioner and an automatic system that reduces the force applied to the occupant.

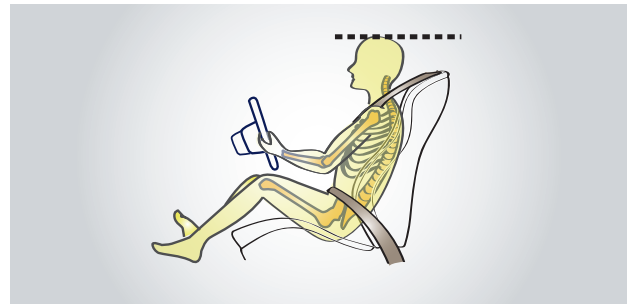
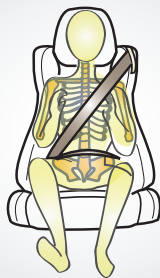



Warning



Do not let the seat belts come into contact with cutting edges. They may get damaged and may consequently break in the event of a collision.

Warning



Each seat belt has been designed to protect only one occupant. If more than one person uses the same seat belt, the risk of injury in the event of an accident is increased.

The seat belt must never be passed around a baby, child or other person sitting on a passenger's lap.

Do not sit babies, small children or other persons on your lap.

If there is a collision, the weight of an adult may cause the child to be crushed by the seat belt causing severe or even fatal injuries.

Warning



Do not attach or pin anything onto the seat belts: they may get damaged and may consequently break in the event of a collision.

Warning



If a seat belt has come into contact with cutting edges or was somehow perforated, we recommend that you have it immediately replaced by the FERRARI SERVICE NETWORK.

Warning



Periodically check the condition of the seat belts. If the belt shows signs of wear, it must be checked by a qualified person and replaced if necessary. Contact the FERRARI SERVICE NETWORK immediately.

2

Pregnant women

The best protection for pregnant women and their unborn babies is to wear the seat belt correctly. This significantly reduces the risk of injury to the baby. As a result, pregnant women must always wear a seat belt unless specifically directed otherwise by a medical practitioner.

The upper part of the diagonal section of the seat belt must lie snug on the front of the shoulder, pass between the breasts down to the abdomen.

The horizontal strap must sit snugly and as far below the abdomen as possible.



How to fasten seat belts

Warning



For an effective restraining action, the seat belt must be fastened correctly with the seat backrest in the upright position.

The seat belt is fastened correctly when the upper part of the belt crosses the centre of the shoulder (not the neck) and the abdominal section is fitted over the hips (not the abdomen).

Make sure it is not twisted and that it passes closely over your body; if not, in the event of a head-on collision, it may move and cause injury to the abdomen.

Avoid wearing bulky clothing that may interfere with the proper operation of the seat belts.

Once you have adjusted the seat correctly (see page 166):

- Grip the latch plate **A**, slowly pull the belt and insert the latch plate into the buckle **B** (if the belt locks while you are pulling it

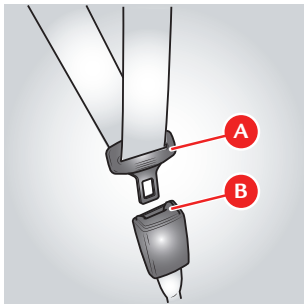

out, let it wind back a little and pull it out again without jerking it).

- Make sure that it has clicked into the locked position: hold the belt and pull it to check that the latch plate has been inserted correctly.
- Position the seat belt correctly.

If the driver's seat belt is not fastened, when the vehicle system is activated (KEY-ON, see page 135), the warning light **D** on the instrument panel lights up and remains lit until the seat belt is fastened.

55 seconds after a speed of 10 km/h is exceeded, a buzzer sounds warning the driver that the seat belt is not fastened.

When a speed of 20 km/h is exceeded, the buzzer activates immediately and stops after 90 seconds.

This acoustic signal is emitted only once, even if the vehicle speed goes above and below the above mentioned limits. It is repeated (when the vehicle speed is in the indicated ranges) only if the seat belt is fastened and unfastened again or, in any case, every time the engine is turned off and then on.

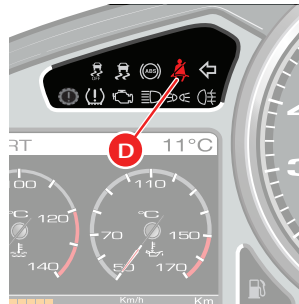



Warning



Each seat belt has been designed to protect only one occupant. If more than one person uses the same seat belt, the risk of injury in the event of an accident is increased.

The seat belt must never be passed around a baby, child or other person sitting on a passenger's lap.

Do not sit babies, small children or other persons on your lap.

If there is a collision, the weight of an adult may cause the child to be crushed by the seat belt causing severe or even fatal injuries.

2

Unfastening the seat belts

- Push the release button **E**.
- Guide the latch plate **A** back to its rest position.

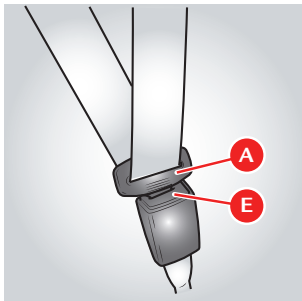



Pretensioners

The seat belts are fitted with pyrotechnic-powered pretensioners. The pretensioner is activated by the airbag ECU where there is:

- a sufficiently severe head-on collision (direction of impact between 11 and 1 o'clock p.m.);
- a sufficiently severe side collision;
- a side roll-over.

The belt will rewind a few centimetres just before the restraining action begins, thereby improving the fitting across the occupant's body.

Activation of a pretensioner is signalled by the illumination of the warning light **A** on the instrument panel.

Warning



If there is a side collision, only the pretensioner on the side where the collision occurs will be activated.

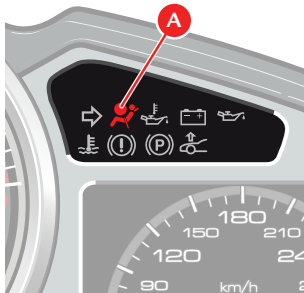

Warning



Pretensioners that have been activated will no longer function and may not be repaired under any circumstances. Contact the FERRARI SERVICE NETWORK for replacement.

When a pretensioner is activated, a small amount of smoke is released. This smoke is not harmful.

Warning



Activation of the pretensioners only depends on the status of the seat belts and is not affected by the occupants' presence.

If the seat belt is not fastened, the pretensioner will not activate, even if the seat is occupied.

The seat belts are fitted with a load limiting device. The load limiting device is located in the belt retractor and allows controlled release of the belt during a collision thereby limiting the impact that the belt has on the occupant's body.



Maintenance of seat belts and pretensioners

- Following a serious collision, replace the seat belts that were worn at the time even if they do not appear to be damaged.
- Periodically check that the screws on the anchor points are tight and that the seat belt is in perfect condition and slides smoothly.
- The seat belt must be kept clean; the presence of any dirt could prevent the seat belt retractor from working properly.
- To clean the seat belt, wash it by hand with mild soap and water and let it dry. Do not use strong detergents, bleach or aggressive solvents, as they can weaken the fibres.

Make sure the retractors do not get wet: proper functioning is only ensured if they are kept dry.

- The pretensioner requires no maintenance or lubrication.

If immersed in water or mud, it must be replaced.

- Pretensioners must be replaced at regular intervals as indicated in the “Warranty Booklet”.

Important note



All work on any part of this safety system must be performed by the FERRARI SERVICE NETWORK.

Warning



Removing or making modifications of any kind to the seat belts, belt retractors and pretensioners is not allowed.

Maintenance work involving strong impacts, vibrations or heating of the pretensioner area may activate them; vibrations caused by road bumps will not have this effect.

2



Auxiliary Occupant Protection Systems (driver and passenger)

Warning



Auxiliary Occupant Protection Systems are not a substitute for seat belts but increase their efficiency. Correct use of the seat belts, with the supplementary action of the Auxiliary Occupant Protection Systems, offers maximum protection in the event of a head-on collision or vehicle roll-over.

Auxiliary Occupant Protection System components (driver and passenger)

The Auxiliary Occupant Protection System components are:

- Seat with built-in headrest.
- Dual-stage front driver's airbag.
- Dual-stage front passenger airbag.
- Driver's head protection side airbag (head bag).
- Passenger head protection side airbag (head bag).
- Driver seat belt (with pretensioner and automatic system to mitigate force applied to the occupant).
- Passenger seat belt (with pretensioner and automatic system to mitigate force applied to the occupant).
- Electronic Control Unit (ECU).
- Additional sensors.
- Instrument panel warning light.
- Deformable body.

The front driver's airbag and front passenger airbag have been designed to increase the level of protection given by the seat belts in the event of a head-on collision (see page 53).

The driver's head protection side airbag and passenger head protection side airbag have been designed to increase the level of protection provided by the seat belts in the event of a lateral collision or side roll-over and form a cushion between the occupant's head and external structures which could penetrate the passenger compartment and cause injury (see page 58).

Warning



When the instrument panel is activated, the warning light **A** will come on when the **START** button is pressed on the steering wheel once. If no malfunctions are detected, it goes out after 4 seconds. If the warning light does not come on, if it remains on or if it comes on while driving, contact the **FERRARI SERVICE NETWORK** immediately.



Front airbags

Warning



The front airbags do not provide protection in the event of side-on collisions, some head-on/angular collisions, roll-overs or subsequent collisions (if there is a second collision once the airbags have been deployed in an earlier collision). The seat belts have been designed to reduce the risk of injury in the event of a roll-over or subsequent collision.

Warning



The front airbags have been designed not to inflate if a minor collision occurs. The seat belts have been designed to reduce the risk of injury if a minor collision occurs.

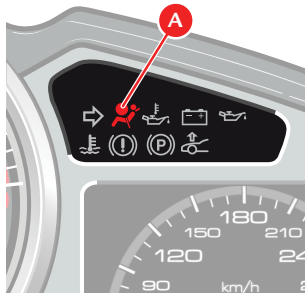

Warning



The driver and the passenger must maintain a distance of at least 25 cm from the steering wheel and the dashboard.

Always drive with your hands on the rim of the steering wheel so that in the event of activation, the airbag can deploy without obstruction.

Driving with your hands on the steering wheel spokes or on the airbag cover increases the risk of injury for your wrists and arms.

2

Warning



The front passenger must be seated correctly and must avoid putting hands, feet or legs on the dashboard since if the front airbag is activated, it may cause injury to legs and prevent the airbag from working properly.

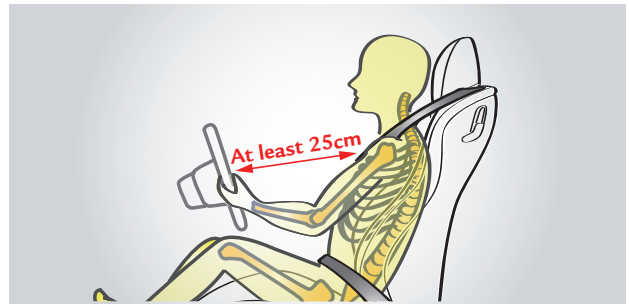



Operation

The front airbags are controlled by an ECU which activates them when there is a sufficiently severe head-on collision (direction of impact between 11 and 1 o'clock p.m.).

In the event of a collision with an impact force that causes deceleration that exceeds the value set for the internal sensor, the ECU will transmit a signal to deploy the airbags. The airbags will begin to inflate, breaking the cover along the breakage line and will deploy completely in a few tenths of milliseconds. Once deployed, they will serve as protection between the driver and/or passenger and structures that could cause injury.

The airbags deflate immediately afterwards.

Warning



The driver and passenger should not carry objects (drink cans or bottles, pipes, etc.) that may cause injury if the airbags are activated.

Persons, animals or items must not be placed between the airbags and the occupant.

Environment



When the system is activated, gases are released in the form of fumes, together with the gas used for inflating the airbags. These gases are not harmful.

The driver's airbag has been designed to be deployed according to the following strategy:

- For low severity crashes, the airbag control unit will not deploy the airbag.

- For crashes of higher severity, the control unit will deploy the driver airbag in low energy mode.
- For crashes of even higher severity, the control unit will deploy the driver airbag in high energy mode.

The passenger airbag has been designed to be deployed according to the following strategy:

- For low severity crashes, the airbag control unit will not deploy the airbag.
- For crashes of higher severity, the control unit will deploy the passenger airbag in low energy mode.
- For crashes of even higher severity, the control unit will deploy the passenger airbag in high energy mode.

Warning



The driver and passenger must always fasten their seat belts and sit in an upright position, as far as possible away from the airbag, in order to have optimal protection in all types of collision.

Warning



Always keep the backrest of your seat in the upright position and sit with your back properly resting against it.

Important note



Do not modify the system components or wiring, under any circumstances.



With the instrument panel activated, although the engine is off, the airbags can still be activated when the vehicle is stationary if it is hit by a moving vehicle.

Remember that if the instrument panel is switched off, none of the safety devices (airbags or pretensioners) will be activated in the event of a collision; failure of the airbags to inflate in these circumstances is not indicative of a system malfunction.

Important note



Do not cut or tamper with the connectors of the airbag harness or on the airbag modules.

Warning



Do not cover the steering wheel and the padded panel on the dashboard on the passenger's side with adhesive tape or treat it in any way.

Warning



Do not place objects above or near the top of the dashboard and the steering wheel. In the event that the airbags are deployed, these objects would be projected into the passenger compartment at a high speed that would seriously jeopardise the safety of the occupants.

Warning



Do not modify the airbag modules in any way (indicated in the relevant picture). Do not damage the airbag modules (for example pinning something onto them or pressing objects against their covers).

If, for any reason, an airbag cover gets damaged, have the airbag module immediately checked by the FERRARI SERVICE NETWORK. Activation of a damaged module could cause serious or fatal injuries.

2

Important note



Do not remove or dismantle parts of the steering wheel, dashboard or door panels; if necessary, this procedure should only be performed by a FERRARI SERVICE NETWORK CENTRE.





Important note



All the airbag system components must be replaced after an accident that caused airbag deployment.

Important note



Following an accident not involving airbag deployment, contact the FERRARI SERVICE NETWORK to have the system checked and any system components replaced.

Important note



The airbag system components have been specially designed only for this specific vehicle model. Do not use them on a different vehicle model, as this may cause serious damage and consequent injury, even fatal, to the occupants in the event of an accident.

Warning



Damaged or defective components of the airbag system cannot be repaired and must be replaced.

Improper operations performed on the system components may cause failures or accidental deployment or failure of the airbags to inflate with consequent damage and injury, even fatal.

Environment



To scrap the vehicle, please contact the FERRARI SERVICE NETWORK to have the airbag system deactivated.

Important note



If the vehicle has been stolen or there has been an attempted theft, have the airbag system checked by the FERRARI SERVICE NETWORK.



Child restraint systems

Warning



The passenger seat is not suitable for installing universal ISOFIX child car seats. You are therefore advised **NOT** to transport babies or young children in this vehicle.

Label **F** on both the sun visors indicates the presence of the airbag system and that rearward facing child restraint systems **must not** be used.

Warning



As indicated on label **F**: NEVER use a rearward facing child restraint system on a seat protected by an ACTIVE FRONTAL AIRBAG. Risk of FATAL or SERIOUS INJURY to CHILDREN.

2





Side airbags

Warning



Airbags are not a substitute for seat belts but they increase their efficiency. Correct use of seat belts, with the supplementary action of the side airbags, offers maximum protection in the event of a collision or side roll-over.

The side airbags will **not** deploy during a front roll-over (Y axis).

Side airbag system components

The vehicle has 2 side airbags, one in the driver-side door and the other in the passenger-side door.

The side airbag system consists of 2 airbags, one on each door. In the event of a side collision or side roll-over, the airbag on the impact side deploys immediately to protect the occupant's head.



Warning



When the vehicle system is activated (KEY-ON, see page 135), the warning light **A** comes on and if no airbag system malfunctions are detected, it goes out after 4 seconds. If the warning light does not come on, if it remains on or if it comes on while driving, contact the FERRARI SERVICE NETWORK immediately.

Operation

The side airbags are controlled by the ECU that activates them when a sufficiently severe collision occurs.

In the event of a side collision with a force of impact exceeding the limit set by the ECU or a side roll-over, this will transmit a signal that activates the pretensioner and the side airbag on the impact side.

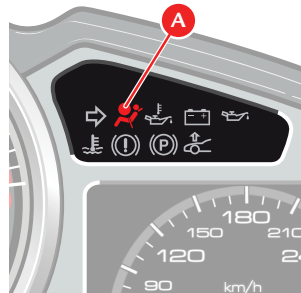



The airbag will start inflating, opening its cover along the breaking line, until it is fully deployed (in a few hundredths of seconds). After deployment, the side airbag will be positioned as a protection between the driver's or passenger's head and the external structures which could penetrate the passenger compartment and cause injury. The airbags deflate immediately afterwards.

Side airbag activation is not affected by the occupant's height or weight. The side bag is activated whenever the airbag ECU detects a collision of a sufficient impact force for deployment.

Warning



Never drive with your head out of the window as this places your head and neck in the airbag deployment area. In the event of a side-on collision, this position increases the risk of being thrown out of the vehicle and compromises the protective effect of the side airbags.

Warning



Never place an object over or near the airbag covers. In the event that the airbags are deployed, these objects would be projected into the passenger compartment at such high speed as to seriously jeopardise the safety of the occupants.

Warning



Never modify the airbag modules. Do not damage the airbag modules or the trim panels covering (upper area of door panel), by pinning objects onto them or pressing objects against their respective covers, for example.

If, for any reason, an airbag cover gets damaged, have the airbag module immediately checked by the FERRARI SERVICE NETWORK. Activation of a damaged module could cause serious injuries.

2

Important note



The airbag ECU is not capable of automatically detecting damage to the airbag covers.

Do not cover the upper part of the driver-door and passenger-door panels with adhesive tape or material and do not treat them in any way.



Warning



After deployment, the airbag components can no longer offer any protection; therefore, they cannot be repaired and must be replaced. After activation of a side airbag, have it replaced by the FERRARI SERVICE NETWORK.

Important note



Never remove the door panel. If required, this operation must be performed by the FERRARI SERVICE NETWORK.

Fuel inertia switch

The fuel inertia switch is a safety device which deactivates the fuel pump relays if a collision occurs.

A symbol appears on the left TFT display and the hazard warning lights come on to indicate that the switch has been activated.

When the fuel inertia switch is activated, the doors are also unlocked (if locked) and the central dome light comes on.

Warning



The fuel pump relays can be reactivated by pressing the button in the battery compartment which can be accessed by opening the passenger side footrest.

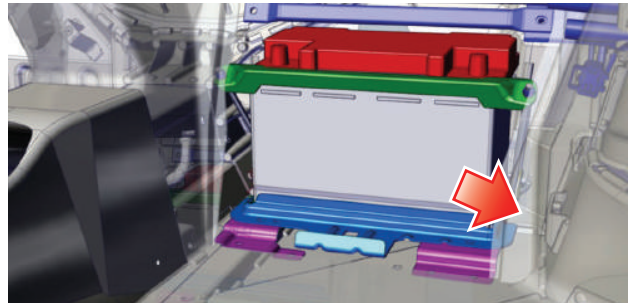



ABS and EBD

The **ABS** system is a safety device which activates to prevent wheel locking if the driver presses the brake pedal too sharply, especially under low grip conditions.

The system is composed of:

- electro-hydraulic unit;
- electronic brake-force distribution **EBD**;
- four speed sensors on the wheels, incorporated in the bearings;
- the entire ESP sensor system (steering angle sensor, accelerometer, yaw sensor, etc.).

These features add to the vehicle's standard braking system, without changing its characteristics.

Important note



When the **ABS** system is active, during emergency braking or in poor grip conditions, a "pulsing" sensation will be felt through the brake pedal. Hold the brake pedal down to continue the braking action.

When one of the wheels starts locking, the hydraulic control unit controls the braking circuit by running a 3-phase cycle:

- reduction (if necessary);
- maintenance;
- pressure increase in the hydraulic circuit.

In the event of **ABS** activation under braking, these regulation cycles will be repeated until the car comes to a stop or pressure on the brake pedal is reduced.

In addition, the system offers the following advantages:

- Driving stability (no skidding): even in the event of sharp braking approaching wheel locking.
- Manoeuvrability (no side-skidding on sharp turns).

This means that even when an emergency situation requires sudden braking, the driver can avoid obstacles, or brake on a curve, without affecting the vehicle stability.

Warning



ABS system performance remains unaltered as long as the speed limit for the tyre side grip is not exceeded. If this limit is exceeded, vehicle skidding cannot be avoided.

- Optimal braking distance:
depending on the type of road surface, the braking distance may be reduced.

Warning



The **ABS** system does **NOT** exempt the driver from driving carefully and responsibly at all times.

2



Important note



The **ABS** system improves braking distances in all conditions, but cannot compensate for the driver's failure to maintain safety distances or loss of control in poor road conditions.

The purpose of the **ABS** system is to maximise the efficacy of the brake system in all situations, and, in particular, at the limit of grip of the tyres and in changing road surface conditions.

FBP - Ferrari Brake Prefill

Brake design parameters provide a set distance between the brake pads and discs (the "air gap"): as soon as the brake pedal is pressed, the presence of the air gap leads to a slight delay in brake response.

The FBP (Ferrari Brake Prefill) system eliminates the air gap by applying slight pressure to the braking system as soon as the accelerator pedal is released just before braking. This results in more immediate brake response and reduces braking distance during emergency braking thereby improving safety.

ESC - Electronic Stability Control

The **ESC** system consists of two main systems:

VDC Vehicle Dynamics Control, performed through the braking system

F1-Trac traction control, performed through engine torque modulation, depending on maximum grip on the road and secondary systems that are always active such as the **ABS** and **EBD**.

To provide optimal control in different driving and grip conditions, four different settings have been developed:

- **Level 1:** (Manettino set to **WET**) ensures stability and maximises traction on every type of road surface, both in low and very low grip conditions, by means of engine and brake control (in this condition, the standard **ASR** system is activated instead of the **F1-Trac** function).
- **Level 2:** (Manettino set to **SPORT**) ensures stability and maximises traction only in medium- to high-grip conditions by optimising engine and brake control.
- **Level 3:** (Manettino set to **RACE**) enhances the racing features of the vehicle by reducing engine control to a minimum and maximising brake control. This mode is designed to ensure stability on the race track in high grip conditions only.
- **Level 4:** (Manettino set to **CT OFF**) further enhances the racing style performance of the vehicle: **F1-Trac** traction control is deactivated whereas stability control remains active when a certain level of sideslip is exceeded. **F1-Trac** traction control is off. Stability is **NOT** guaranteed.
- **Level 5:** (Manettino set to **ESC OFF**) **ESC** off. Stability is **NOT** guaranteed, but all other auxiliary systems such as **ABS**, **EBD** and the **E-Diff 3** electronic differential remain active. The **VDC** system remains active under braking.

Important note



Track use refers to occasional use of the vehicle. The vehicle is **NOT** intended for more frequent and continuous use on the track.





F1-Trac

F1-Trac is a traction control system that derives directly from FERRARI's expertise in F1 vehicles.

F1-Trac is faster and more accurate than traditional control systems and is capable of delaying and minimising engine torque adjustments as required in order to ensure the desired trajectory.

The system estimates the maximum available grip in advance, by continuously monitoring the relative wheel speed and using an auto-adaptive operating logic. Comparing this information with the vehicle dynamics model stored in the control system, **F1-Trac** optimises the vehicle behaviour by controlling engine torque delivery.

Important note



F1-Trac does not work when the Manettino is set to CT OFF and ESC OFF driving modes.

The main feature that distinguishes the F1-Trac system from a traditional traction control system lies in its ability to estimate grip level accurately which allows the driver to make full use of the vehicle's performance driving potential.

The **F1-Trac** system guarantees:

- maximum traction when coming out of bends;
- driving stability and ease even under extreme driving conditions;
- driving comfort.

On this vehicle, integration of the **F1-Trac** and E-Diff 3 systems ensures maximum performance and stability.

E-Diff 3

The vehicle is equipped with an electronic differential, working on the rear axle, which continually performs a variable check on the locking between the two axle shafts.

The electronic differential system, integrated with **F1-Trac** traction control, is capable of improving:

- performance;
- directional stability of the vehicle;
- active safety even when close to grip limit;
- driving comfort and handling.

The system is based on the analysis and forecast of vehicle performance in all possible conditions. This is done by continually monitoring the pressure of the clutch actuator on the differential.

The input signals are the dynamic parameters of the vehicle that the control system translates into a torque difference between the two driving wheels.

On bends, the electronic differential can:

- stabilise the vehicle when the accelerator pedal is released by locking the rear axle;
- control vehicle dynamics by locking the differential according to lateral acceleration and vehicle speed;
- maximise vehicle stability and, at the same time, acceleration on bends by locking the differential according to lateral acceleration, speed, engaged gear and torque produced by the engine.

To obtain these results, the electronic differential system interacts with the **F1-Trac**, **ESC** and **ABS** systems, F1 gearbox and suspension damping control.

2



EPB - Electric parking brake

On this vehicle the parking brake is actuated by an electric motor. The parking brake can be applied and released by pulling a special lever **B** on the dashboard to the left of the steering wheel. When the instrument panel is activated, a special warning light comes on on the panel to indicate that the parking brake has been applied (see page 108).

Pull the lever **B** while holding the brake pedal depressed to release the parking brake. If the instrument panel is activated, the warning light goes out when the parking brake has been fully released.

The electric parking brake may be used as an emergency brake when the vehicle is in motion. If this is the case, the system acts on all four wheels until button **B** is released by communicating with the ESP system which prevents locking.

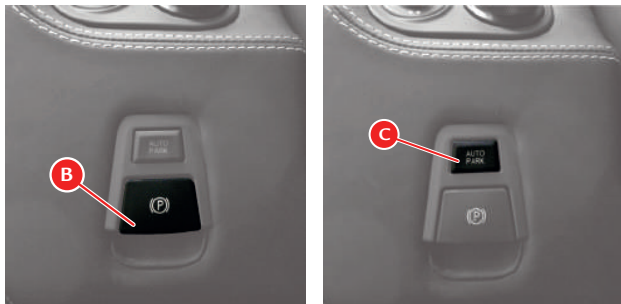

Warning



Always apply the parking brake when the vehicle is parked.
The vehicle should be blocked. If this is not the case, please contact the **FERRARI SERVICE NETWORK**.

Autopark Function

The EPB Autopark function automatically activates the electric parking brake when the engine is switched off. This means that the driver does not have to apply the parking brake every time the engine stops.

However, the function can be temporarily deactivated before switching off the engine by pressing the **AUTO PARK C** button: the message “PARK OFF” is displayed on the left TFT display for 5 seconds. In this case, after the engine is switched off, the parking brake must be engaged manually by pulling the lever **B**. To re-enable automatic EPB engagement at the next key-off, press the button **C** again; the message “PARK ON” is displayed on the left TFT display for 5 seconds.

“Automatic Vehicle Holding” AVH function

The electric parking brake provides optimised release when the vehicle starts up due to its Automatic Vehicle Holding function: once the engine has started, the system keeps the vehicle braked through intervention of the braking system rather than through the parking brake shoes.



Tyre temperature and pressure monitoring system TPMS

The vehicle is equipped with a system that measures the tyre pressure and temperature using special sensors fitted inside the wheel rims next to the air valve. These sensors transmit a signal that is received by the antennas on the car body, behind the gravel guards, that are connected to the ECU.

Important note



The system may be momentarily affected by radioelectrical interference from devices that use similar wavelengths.

The ECU processes this information and transmits data on tyre pressure and temperature and any system errors to the instrument panel.

The signal transmitted by the ECU activates symbols on the left TFT display with two priority levels: a **soft warning** (SW) if the pressure loss is **0.2 bar more** than the rated pressure and a **hard warning** (HW) if it is **0.5 bar more** or there is a dynamic decrease of over 0.2 bar/min.

The TPMS can be calibrated using the special menu item in the left TFT display (see page 86).

Important note



System calibration using the special menu item on the left TFT display is necessary after replacement or inflation of a tyre or tyres.

Warning



The TPMS warns the driver that the tyre pressure has decreased. However, this does NOT exempt the driver from periodically checking that the tyres are inflated to the indicated pressure.

In addition, the system does NOT warn the driver of damage to the tyres by external agents.

2

Displaying messages on the left TFT display

By using the commands on the left TFT display (see page 84), the driver can access the TYRES screen page which displays the vehicle symbol with the pressure and temperature values of each tyre as shown in example 1.

Example 1

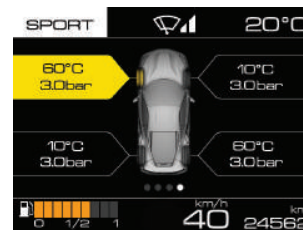



If the TYRES screen page is being displayed and an event occurs that needs to be shown as a symbol and/or special message, the screen page is minimised as shown in example 2. For further information, refer to the paragraph “Fault visualisation logic” on page 101.

Low pressure

Regardless of the type of screen page on the left TFT display, when the instrument panel receives the signal from the tyre pressure ECU that the pressure level of one or more tyres is below the alarm threshold, the screen page shown in example 3 (for a warning related to only one tyre) or example 4 (for a warning related to several tyres) appears immediately.

The screen page is displayed for 20 seconds and then the screen page that was previously displayed reappears. If the failure persists, the screen page shown above (example 3 or 4) will be automatically displayed for 20 seconds the next time the engine is started.

The driver can call up the TYRES screen page at any time to display which tyres have low pressure (example 5).

Example 2

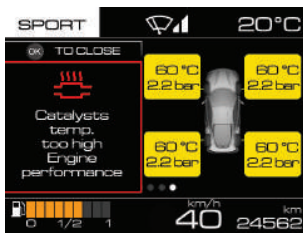

Example 3

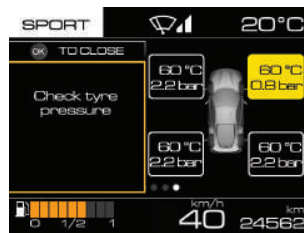

Example 4

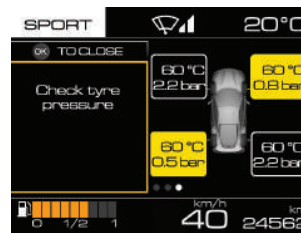

Example 5

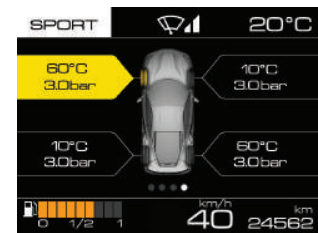



Occasionally, the system may not detect which wheel signals a failure. If this is the case, then only the message “Check tyre pressure” will be displayed as shown in example 6.

Tyre puncture

Regardless of the current active page on the left TFT display, when the instrument panel receives the signal from the tyre pressure ECU that the pressure level of one or more tyres is below the alarm threshold, the specific screen shown in example 7 (warning not to proceed) is displayed immediately. At the same time, a warning light comes on on the panel (see page 107) in fixed mode.

Warning



If you have a puncture, stop driving

The screen page is displayed for 20 seconds and then the screen page that was previously displayed reappears whereas the warning light on the instrument panel remains on in fixed mode.

The fault is displayed with the same display logic applicable for other priority 0 faults (see the paragraph “Fault visualisation logic” on page 101) until the correct operating conditions are restored and the system is subsequently recalibrated.

If you call up the TYRES screen page, you can identify the punctured tyre at any time (example 8).

2

Example 6

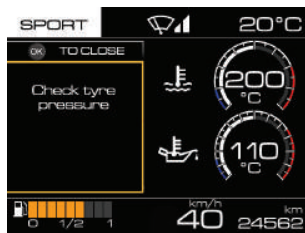

Example 7



Example 8

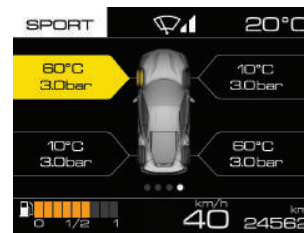



System not calibrated

If the system has not been calibrated or one or more tyres have been replaced, the symbol and message shown in example 9 will be displayed. Simultaneously, the specific warning light on the instrument panel (see page 107) starts flashing, and continues to flash for 90 seconds.

When the display cycle ends (20 seconds), the symbol and message disappear and the screen page that was previously displayed reappears whereas the warning light remains on until the system has been calibrated.

The TPMS can be calibrated using the special menu item on the left TFT display with the instrument panel activated and the engine off.

To calibrate the TPMS, call up the MENU screen page on the left TFT display (see page 86) with the instrument panel activated and the engine off. Once the MENU screen page appears, select the items “Car setup”, “Calibr. TPMS”.

When the Menu item is displayed and the subsequent calibration accepted, the screen page shown in example 10 appears for 5 seconds.

Example 9



Example 10



Example 11



Warning



Before calibrating the system, make sure that the tyre pressure corresponds to the indicated pressure values (see page 33). If this is not the case, the TPMS may issue wrong low pressure indications.

TPMS failure

The screen page shown in example 11 is displayed in the following circumstances:

- malfunction in the circuit and/or wiring connecting the ECU;
- signal is not received by one or more sensors due to a faulty, broken or flat battery;
- fault in the TPMS ECU.

Simultaneously, the specific warning light on the instrument panel (see page 107) starts flashing, and continues to flash for 90 seconds. The warning light then remains on in fixed mode until the situation is corrected.

The TYRES screen page cannot be called up by the driver.



System temporarily not active

The screen page shown in example 12 is displayed in the following circumstances:

- overheating of sensors;
- during calibration (the TPMS ECU does not recognise the sensors);
- radio frequency that interferes with the wheel sensor signal.

Simultaneously, the specific warning light on the instrument panel (see page 107) starts flashing, and continues to flash for 90 seconds. The warning light then remains on in fixed mode until the situation is corrected.

The TYRES screen page cannot be called up by the driver.

System not active

If the TPMS has been deactivated by a diagnostic tool, when the instrument panel is activated, the screen page in example 13 is displayed for a few seconds.

Simultaneously, the specific warning light on the instrument panel (see page 107) starts flashing, and continues to flash for 90 seconds. The warning light then remains on in fixed mode until the situation is corrected.

The TYRES screen page cannot be called up by the driver.

2

Example 12

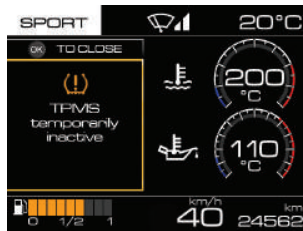

Example 13



Doors	74
Engine compartment lid.....	76
Luggage compartment lid	77
Fuel filler flap and neck	79
Power windows	81
Instruments and gauges	82
Cruise control.....	116
Controls on the steering wheel	118
Active aerodynamics (DRS).....	120
Side Slip angle Control (SSC2)	121
Suspension damping delink button.....	122
Windscreen wipers.....	123
Lighting.....	126
Driving the vehicle	132
EPB - Electric parking brake	152
Park Lock	154
Launch Control	155
Stop&Start system (optional).....	156
Seat adjustment	166
Air conditioning and heating system	176
Passenger compartment accessories	180
Infotainment system	182



ABOUT YOUR VEHICLE





Controls overview



Ref.	Control	Page	Ref.	Control	Page
1	Adjustable air vents	179	4	Light switch	126
2	Glove compartment	170	5	Electric parking brake (EPB) control	152
3	Climate control system control panel	176	6	Left TFT display controls	84



Ref.	Control	Page
7	Left TFT display	84
8	Rev counter and gearbox display	83-110
9	Right TFT display	112
10	Turn indicators	128
11	Windscreen washer/wiper lever	123
12	“Manettino” control	118-142
13	ENGINE START/STOP button	116
14	Suspension damping delink button	120-146
15	High beam and flashing lever	126

Ref.	Control	Page
16	Power window controls	81
17	Hazard warning lights control	129
18	“R” reverse control	137
19	“AUTO” control	140
20	“LAUNCH” control	155
21	Air conditioning controls	176





Doors

When a door is opened or closed, the window automatically moves down by approximately 2 centimetres (to its “target position”) to avoid colliding with the upper weather strip.

When the door is closed, the window automatically moves up until it reaches the “upper limit”.

Opening from the outside

Using the remote control, deactivate the alarm and the central door locking system, or turn the metal blade on the key in the lock to deactivate the central door locking system.

To open the door, pull handle **A**: the window will move down to its “target position”. When the door is closed, the window will move up until it meets the upper limit.

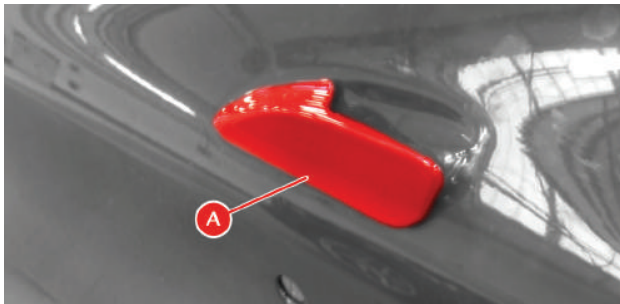

Locking and opening the doors from the inside

Warning



Always carefully check manually that the doors have been closed properly to prevent them from opening while driving.

Both doors can be locked by activating/deactivating the “LOCK/UNLOCK” **B** button on the roof panel. To lock the doors, press button **B**; when the door lock is activated, the light on button **B** comes on. To deactivate the door lock, press button **B** until the light goes out.

The rolling lock function, which automatically locks the doors when the vehicle speed reaches or exceeds 20 Km/h, may be activated from the “Car setup” menu accessible from the left hand TFT display of the instrument panel (see page 86).

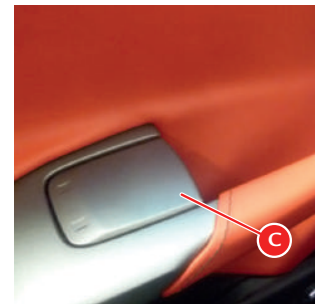
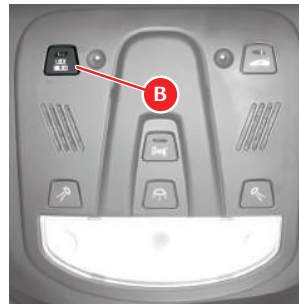



If you pull handle **C** to open the door, the window will move down to its target position. When the door is closed, it will move up until it meets its upper limit.

If handle **C** is lifted without opening the door, the window will move down to its target position and stop and if the door is not opened after 2 seconds, the window will move back up until it meets the upper limit. Therefore, to open the door, release handle **C** and pull it again.

When the opening handle is operated, both doors are unlocked.

3



Engine compartment lid

Opening

Pull the release lever **D** on the underdoor footrest on the driver side.

Lift the engine compartment lid.

The lid is held open by two gas struts **E**.

The engine compartment lid can also be opened when the key battery is flat.

Closing

Lower the lid until it is closed and press down near the lock until you hear it click in place.

Warning



Always check manually that the engine compartment lid has been closed properly to prevent it from opening while driving.

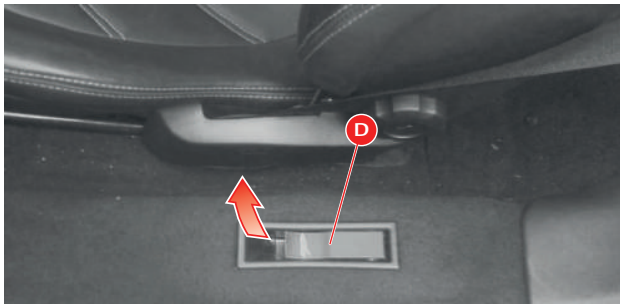



Luggage compartment lid

Opening

The luggage compartment lid can also be opened when the key battery is flat.

Push the release button **F** on the inner side of the driver door or press and hold button **G** on the ignition key for more than 2 seconds.

Stand in front of the vehicle, slightly lift the lid and pull the retaining lever **H** to lift it completely.

The lid is held open by two gas struts **L**.

The luggage compartment is illuminated by two light units which activate automatically when the luggage compartment lid is opened.

Important note



After removing the battery from the vehicle or disconnecting it from the electrical system, a door lock/unlock cycle must be performed using the buttons on the key when reconnecting so that the release button **F** resumes normal operation (electronic system self-acquisition procedure).

3

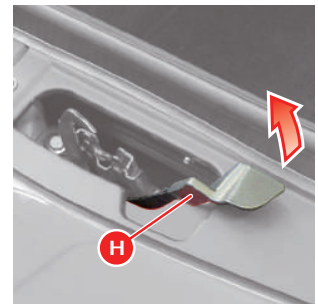
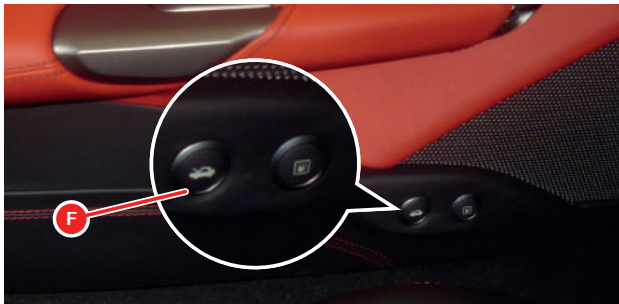



Closing

Lower the lid until it is closed and press down near the lock until you hear it click in place.

Warning



Always check that the luggage compartment lid has been closed properly to prevent it from opening while driving.

Emergency Opening

If the luggage compartment lid opening button does not work, there is a string for manual emergency opening underneath the dashboard to the left of the steering wheel as shown by the arrow in the figure.





Fuel filler flap and neck

Warning



Always turn off the engine during refuelling.

Do not smoke or use naked flames when refuelling. There is a risk of fire.

The following can be harmful for your health:

- fuel coming into contact with your skin;
- inhaling fuel vapours.

Opening

To open the fuel filler flap, press button **M** on the inner side of the driver door.

Closing

To close the fuel filler flap, push it until it clicks in place.



Emergency Opening

If the opening button does not work, the fuel filler flap can be opened manually by pulling the cable **P** on the right-hand side of the engine compartment.

3

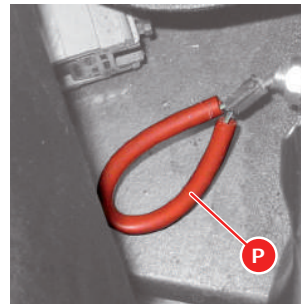



Capless filler neck

This vehicle has a capless filler neck for fuelling. This system allows you to refuel by opening the fuel filler flap and simply placing the nozzle in the filler neck without having to unscrew a cap and screw it up again.

Two flaps placed in series, both with airtight seals, act as a cap. The external flap is locked by a series of “teeth” and the only way to open the external flap correctly is by inserting a petrol pump nozzle.



Warning



Place the nozzle in the filler neck carefully to avoid damaging the device seal.

Do not try to open the external flap of the filler neck by pushing it with your fingers or lever it open using unsuitable tools (e.g. screwdrivers). This may damage the external flap mechanism, compromising the seal integrity and safety of the system.

Warning



Do not overfill the fuel tank: this may cause the fuel to leak out. After fuelling, wait for about 5 seconds before slowly removing the nozzle from the filler neck: in this way, the last drops of fuel will flow into the tank and will not drip onto the vehicle.

Warning



Do not place funnels or portable container nozzles in the filler neck.

If you need to refuel from a portable fuel container, use only the funnel supplied in the tool bag (see page 202) that releases the automatic closing device.



Power windows

The power windows can only be used when the vehicle system has been switched on (press and quickly release the ENGINE START/STOP button on the steering wheel without pressing the brake pedal) or the engine has started (see page 135).

Driver-side power window

Press button **A** to move the window up or down.

This allows manual operation (partial opening/closing) or automatic operation (complete opening/closing): press button **A** and quickly release to activate manual operation; if the button is pressed at length (over 0.3 seconds), automatic window operation is activated. The window will only stop when it reaches the end of its travel or by pressing the button again.



Passenger-side power window

Press button **B** to move the window up or down.

Only manual operation is possible (partial opening) to raise the window: when button **B** is released, the window stops at the position reached.

To lower the window, automatic operation is also possible (full opening): if the button is pressed at length (over 0.3 seconds) automatic window operation is activated. The window will only stop when it reaches the end of its travel or by pressing the button again.

When the door is open, the window moves down to its “target position”; this is to prevent the window from colliding with the upper weather strip when it is closed.

Warning



Improper use of the power windows may be dangerous. Before use, always check that people and objects are at a safe distance.

Pay particular attention during the automatic operation of the driver-side power window.

3



Instruments and gauges

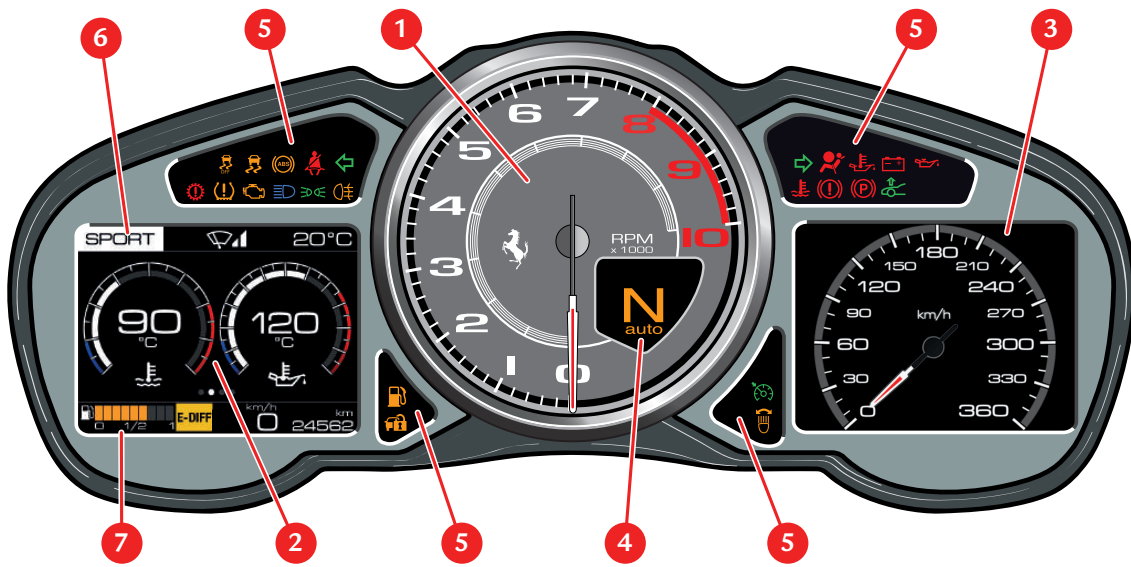



Electronic rev counter

The electronic rev counter indicates the engine RPM. The numbers on the dial multiplied by 1000 correspond to the engine RPM in one minute.

Avoid engine speed rates in the red sector.

There is a space to the bottom right of the rev counter for the display which gives information on dual clutch transmission (DCT).

3

- 1 Electronic rev counter
- 2 Left hand TFT display
- 3 Right TFT display
- 4 Gear display
- 5 Warning lights on the panel
- 6 Manettino status
- 7 Fuel level



Left TFT display

Located on the instrument panel, it performs the following functions:

- displays the control parameters;
- displays general information while driving;
- displays fault warnings.

The driver can interact with the system by selecting the configuration and setting the parameters using the controls on the dashboard to the left of the steering wheel.

The display is activated and set by pressing the following buttons:

- TURBO (A),
- VDA (B),
- BACK (C),
- OK (D),
- UP, DOWN, LEFT, RIGHT (E).

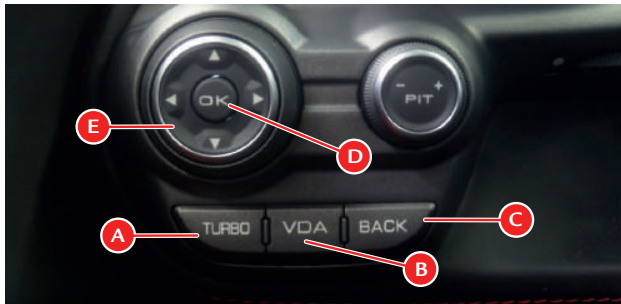

Main left TFT menu

The “Main menu” screen page can be used to access the five screen page groups STATUS, TRIP, VDA, TURBO and SETTINGS. These groups contain the following screen pages:

STATUS

- SPORT screen page
- SPORT 2 screen page
- TYRES screen page
- SPEEDOMETER screen page
(only when the infotainment system is activated).

TRIP

- TRIP A
screen page TRIP B screen page.

VDA

- VEHICLE STATUS screen page
- MANETTINO STATUS screen page
- CHRONOMETER screen page
(not available if vehicle is equipped with FERRARI TELEMETRY).





TURBO

- TURBO screen page (indicates turbo pressure)
- TURBO RESPONSE screen page
- TURBO EFFICIENCY screen page.

SETTINGS

- SETUP screen page.

Press the **RIGHT** and **LEFT** buttons to sequentially switch between screen pages in a group. Press **RIGHT** to go to the next screen page (for example, in the **STATUS** group from **SPORT** to **SPORT 2**) and press **LEFT** to go to the previous screen page.

When a screen page is called up, it remains on the display until you decide to select another one. To move up the menu levels, press the **BACK** button and go back to the “Main menu” screen page.

Every screen page consists of four display areas:

- A** - selected driving mode (Manettino position), DRS status, windscreen wiper status, external temperature and “ice hazard” icon, “Speed limit exceeded” message.
- B** - display of virtual control gauges, parking sensor screen page, display of abnormal events/warnings (message text and special symbol, when available), display of brightness adjustment function.
- C** - total or trip odometer (TRIP A or B), range.
- D** - fuel level gauge, area for minimised symbol for faults that do not have a specific warning light on the panel (see page 101), speed repetition.

3

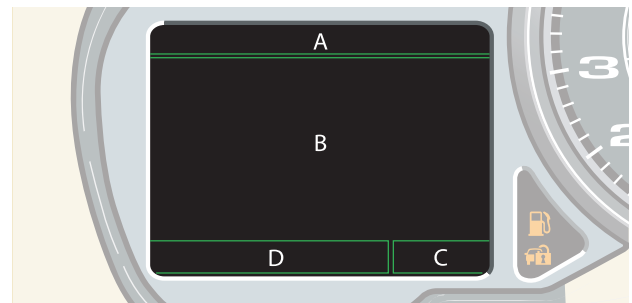



Display setting and configuration of vehicle parameters

Warning



Most of the display settings can only be adjusted and the parameters configured when the vehicle is stationary. When the vehicle is in motion, you can only adjust the display brightness and set the speed limit.

SETUP screen page

Display setting and configuration of the various vehicle parameters is possible using the MENU screen page (the only screen page in the SETUP group).



Navigation within the menu is on several levels; the first level offers a list of items through which the following parameters can be set or the following information can be displayed:

- **Dimming:** display dimming setting.
- **Right display:** right display setting.
- **Date/Hour:** date and time setting.
- **Language:** language setting.
- **Unit of measurement:** unit of measurement setting.
- **Car setup:** vehicle parameter configuration.
- **Service:** information on scheduled maintenance.
- **TPMS calibration:** TPMS system calibration

These items are the main menu functions. To scroll through the list of items, press the UP and DOWN buttons; to select the required function, press and quickly release the OK button or the RIGHT button.

Once the function has been selected, the individual subfunctions or parameters that can be activated are displayed. To select them, use the UP and DOWN buttons and press and quickly release the OK (or RIGHT) button to activate a subsection or activate the selected parameter.

To go back to the previous menu level, press the BACK button. If no operation is performed for at least 10 seconds, the previous menu level reappears on the display.

Adjusting brightness

The brightness setting of the two TFT displays on the instrument panel is adjusted from the specific option in the SETUP screen.



Fuel level gauge

The fuel level gauge is always displayed in area **D** of the display (see page 85). The gauge has 9 yellow bars that gradually “turn off” as the fuel level drops.



When the second bar goes off, the first bar turns red until fuel runs out.



When the reserve fuel is reached, in addition to the activation of the relative warning lamp on the instrument panel (see page 104), the relative symbol and specific message, together with the remaining range in Km, are shown on the display for 10 seconds. If the condition that has generated it persists, this signal is repeated every 8 km.

In limited cruising range conditions, the information on driving range in km is replaced by the words “Limited cruising range”.

3

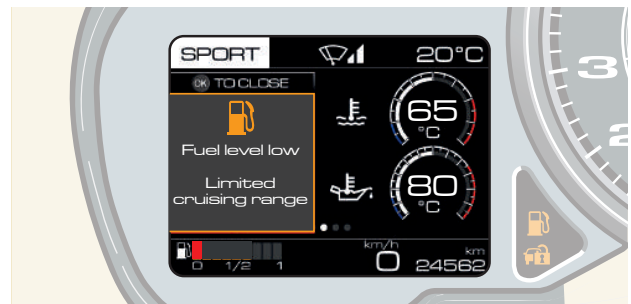
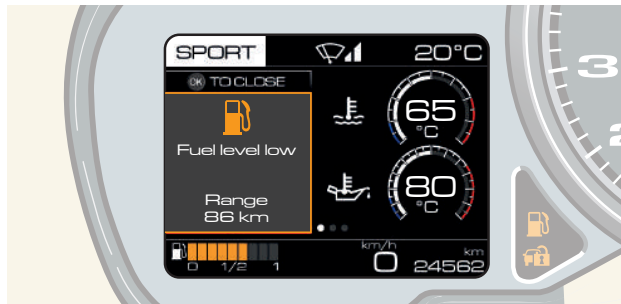



TURBO screen page

The TURBO menu can be activated by pressing the TURBO button on the right satellite or by selecting the special item from the main menu on the left TFT display. The TURBO function has 3 screen pages:

- **TURBO**: indicates the working pressure of the turbocharger.
- **TURBO RESPONSE (TR)**: indicates the percentage of maximum engine response available to the driver depending on the number of revs. For instance, using the gearbox and accelerator pedal to push the engine to over 4000 RPM gives a very high % of TR (80-90%); pressing the accelerator pedal hard down will give instant engine response and acceleration.

- **TURBO EFFICIENCY (TE)**: indicates the percentage of maximum turbo efficiency (seen as the maximum torque obtainable by the car for a given fuel consumption level or specific amount of fuel used) available to the driver depending on the number of revs.

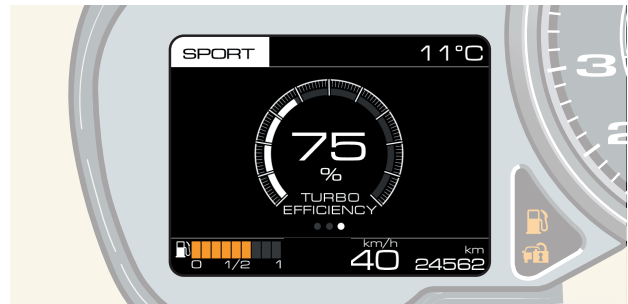
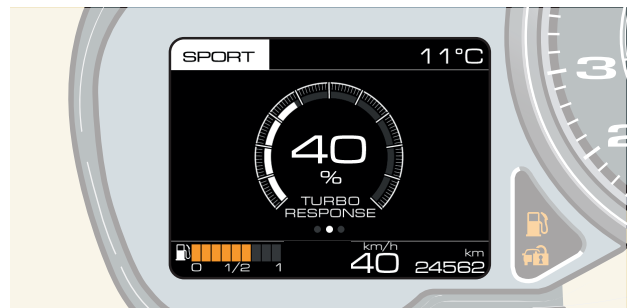
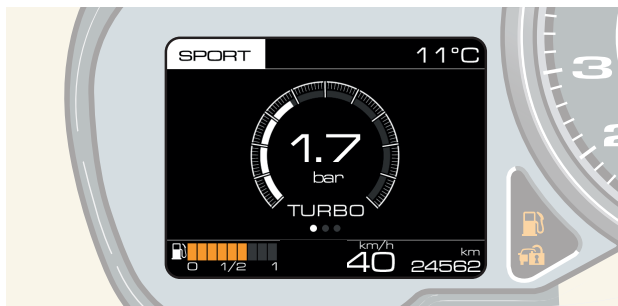



SPORT screen page

The SPORT screen page displays the following virtual gauges:

- Engine coolant temperature.
- Engine oil temperature.

If the SPORT screen page is being displayed and an event occurs that needs to be displayed as a symbol and/or special message, the virtual gauges are minimised. For further information, refer to the “Fault displaying logic” paragraph on page 101.

SPORT 2 screen page

The SPORT 2 screen page displays the following virtual gauges:

- Engine oil pressure.
- Voltmeter.

If the SPORT 2 screen page is being displayed and an event occurs that needs to be displayed as a symbol and/or special message, the virtual gauges are minimised. For further information, refer to the “Fault displaying logic” paragraph on page 101.

3

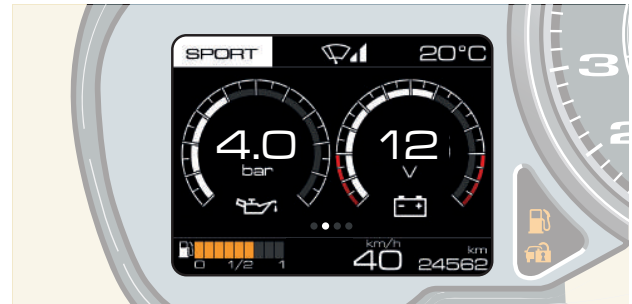
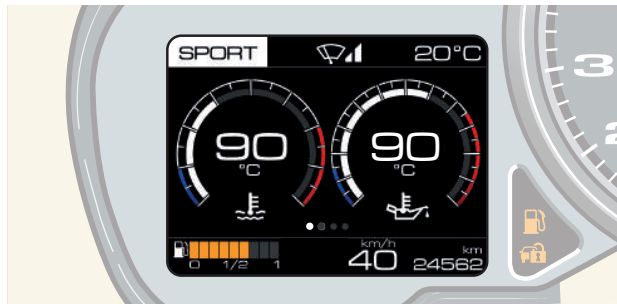



TYRES screen page

The TYRES screen page displays a symbol of the vehicle with the pressure and temperature values for each tyre.

If the TYRES screen page is being displayed and an event occurs that needs to be displayed as a symbol and/or special message, the screen page is minimised. For further information, refer to the “Fault displaying logic” paragraph on page 101.

VDA (Vehicle Dynamic Assistance) screen page group

In addition to its chronometer function, the Vehicle Dynamic Assistance (VDA) screen page group provides a valid support for assessing vehicle status when on the track and can be used to intuitively understand the most suitable conditions for performance driving. The VDA group, which is recalled by selecting the icon in the “Main menu” or directly by pressing the VDA button with any screen page displayed, consists of the “Vehicle status”, “Manettino status” and “Chronometer” screen pages.

The “Vehicle status” screen page functions are only available when the “Manettino” driving mode control switch (see page 118) is set to RACE, CT OFF or ESC OFF, positions developed especially when using the vehicle on track; however, if the Manettino is set to WET or SPORT mode, the “Vehicle status” screen page is displayed along with the message “VDA not available in WET - SPORT”.

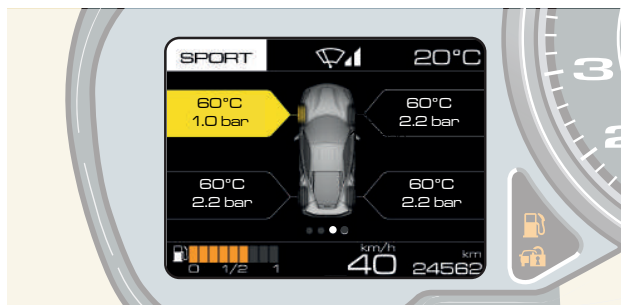



Vehicle status screen page

The “Vehicle status” screen page, which is directly called up by pressing the VDA button or by selecting the special item in the “Main menu”, is intended to help the user bring the vehicle to optimum performance when driving on high grip surfaces. This is made possible by an algorithm that determines the thermal state of the main vehicle subsystems (tyres, brakes and engine) in relation to the dynamics of various parameters (lateral acceleration, speed, etc.). The status of the vehicle is displayed concisely using three levels which are blue, green and red:

WARMUP

Warm-up stage for components and self-acquisition of control systems; during this stage, the vehicle should be driven so that it is taken to optimum conditions of use.

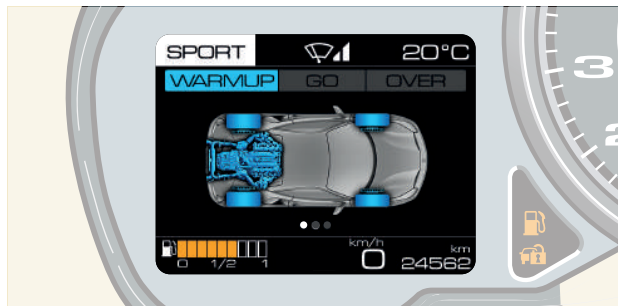

GO

The vehicle has completed the warm-up stage: all its subsystems have reached optimum conditions of use for performance driving.

OVER

One or more systems have reached an overheating condition that may affect vehicle dynamics. Slowing down is therefore recommended to restore these systems to optimum conditions of use.

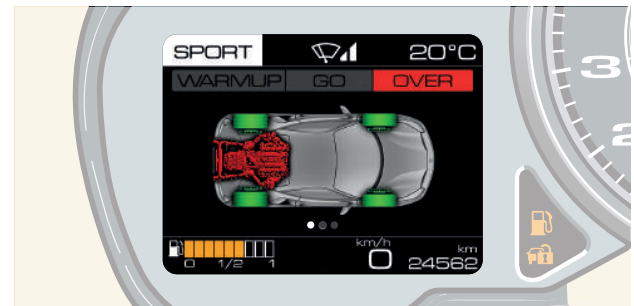
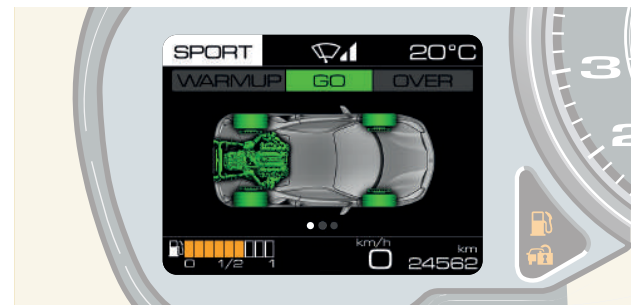

3



After each start, the ESC stability and traction control system compensates for the tyre rolling radius and detects the spare wheel. While this procedure is being performed, the Vehicle Status screen page indicates to the driver that system self-acquisition is in progress by displaying the message “ESC autolearning”.

Warning



Test-driving the vehicle on the race track: after each start, cover the first straight stretch of the track (at least 500 meters) at a constant speed so that the ESC stability and traction control system can calculate exactly the grip available and the rolling radius of the tyres (the calculation is reset every time the engine stops).

If this rule is not followed, system performance may be reduced.

If one or more signals related to the performance parameters used to calculate the thermal state of the subsystems (lateral acceleration, speed, etc.) are not valid, the Vehicle Status screen page indicates to the driver that the function is not available by displaying the message “Function not available”.

Manettino status screen page

The “Manettino status” screen page displays a list of parameters which can be configured using the “Manettino” driving mode control switch (see page 118) and indicates the configuration each one assumes in a specific driving mode.

The systems involved are the following:

- **F1-Trac**: traction control.
- **E-Diff**: electronic differential.
- **F1-DC**: dual clutch F1 gearbox.
- **ESC**: stability and traction control.
- **ABS**: anti-lock braking system.
- **SCM**: magnetorheologically controlled suspension.

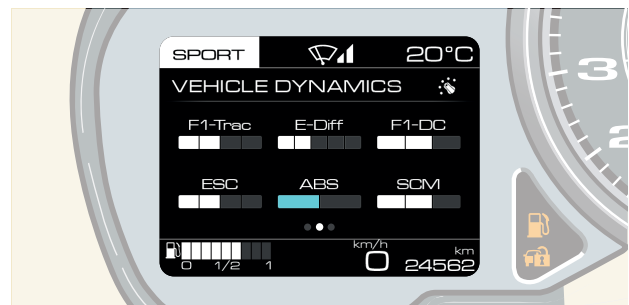



If one of the other two VDA screen pages is displayed (“Chronometer” or “Vehicle Status”), the “Manettino Status” screen page is displayed in timed mode for 3 seconds when the position of the Manettino is changed so that the driver is informed of the new status that the systems are in. After 3 seconds, the screen page that was previously displayed reappears.

The “Manettino status” screen page is also automatically displayed in timed mode at KEY-ON if one of the other two VDA screen pages was displayed at the previous key-off and the Manettino was in a different position from the current one.

Important note



If there is a Manettino failure, the “Manettino Status” screen page cannot be displayed or recalled.

Chronometer screen page

The “Chronometer” screen page (not available if vehicle is equipped with FERRARI TELEMETRY) is used to time laps and memorise lap times when the vehicle is used occasionally on track. The screen page displays the following information:

Current Lap

indicates the time elapsed since the start of the chronometer.

LAP TIME / Best

indicates the time required to complete the last best lap.

LAP TIME / Last

indicates the time required to complete the last lap.

TOP SPEED / Best

indicates the maximum speed reached.

TOP SPEED / Last

indicates the maximum speed reached in the last lap.

If the “Chronometer” screen page is being displayed and an event occurs that needs to be displayed as a symbol and/or special message, the screen page is minimised.

3

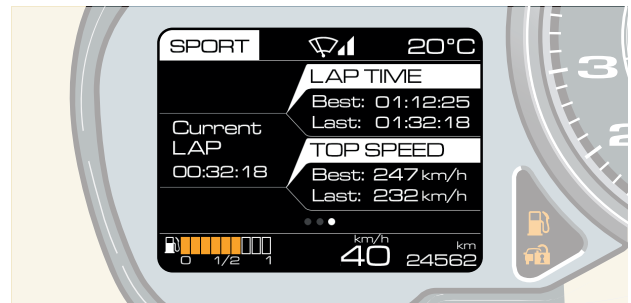



For further information, refer to the “Fault displaying logic” paragraph on page 101. During display of the event/malfunction, the chronometer remains active.

The chronometer always resets each time the ignition switch turned on, while the last valid Best Lap, Best Speed, Last Speed and Last Lap information is memorised.

Chronometer operating logic

The chronometer is controlled using the OK, UP and DOWN buttons that perform the following functions:

- Pressing and quickly releasing the OK button:
 - when the chronometer is off, starts the Current Lap chronometer
 - when the chronometer is on, resets and restarts the Current Lap and updates the information on previous laps (end of lap/start of next lap).
- Pressing and quickly releasing the UP or DOWN button:
 - when the chronometer is on, stops the chronometer and updates information on previous laps.
- Holding down the UP or DOWN button:
 - when the chronometer is on or off, resets the chronometer and information on previous laps.

Note that during display of an event/malfunction, pressing and quickly releasing the OK button interrupts the event/malfunction display cycle (“ESCAPE” function), without affecting the chronometer.



TRIP A and TRIP B screen pages

The TRIP A or TRIP B screen page displays the following information:

- Maximum speed
- Average speed
- Travel distance
- Travel time
- Range

To reset the TRIP A or TRIP B screens, press and hold down the OK button.

If the TRIP A or TRIP B screen page is being displayed and an event occurs that needs to be displayed as a symbol and/or special message, the screen page is minimised. For further information, refer to the “Fault displaying logic” paragraph on page 101.

Ferrari Telemetry (optional)

The FERRARI TELEMETRY system (optional) is used to acquire information on driving on a specific track in real time so that it can then be presented to the driver and compared and analysed according to a number of parameters. Information acquired by different drivers while driving on the same track can also be compared.

Important note



For more information on the FERRARI TELEMETRY System, refer to the printed TELEMETRY user manual or the document in PDF format on the FERRARI TELEMETRY USB key.

3

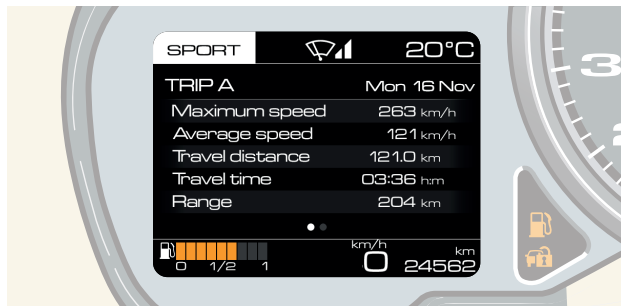



“Warning: danger of ice” message

To warn the driver of the presence of ice on the road if the outside temperature is 3 °C (38 °F) or below, the “snow” symbol is displayed for 10 seconds in the top right of the display.

When they are displayed, the symbol and message appear instead of the outside temperature; after 10 seconds, the outside temperature is displayed again and the “snow” symbol appears next to it as long as the outside temperature remains 6 °C (43 °F) or below.

Speed limit setting and “Speed limit exceeded” message

The MENU screen page can be used to set a speed limit in the range 30 - 250 km/h (17 - 155 mph) with 5 km/h (3 mph) steps which sends a message to the driver when exceeded. To set the speed limit, call up the MENU screen page by pressing the **UP** button when the MAIN screen page is activated. Select the options “Vehicle Config.” and “Speed Limit” (the only menu function that is configurable while the vehicle is in motion). To set the value, use the **UP** and **DOWN** buttons.

When the minimum limit of 30 km/h (18.6 mph) is reached, press the **DOWN** button again to deactivate the function or press the **UP** button after reaching the maximum speed of 250 km/h (155 mph). The function is normally deactivated (OFF).

When the set limit is exceeded, the driver is informed in the following way:

The symbol showing the set limit and a “Speed limit exceeded” message appear in the top right of the display for 10 seconds accompanied by an acoustic signal. Once the warning cycle has ended, the message disappears whereas the symbol continues to be displayed next to the outside temperature until the speed decreases to 5 km/h below the set limit.

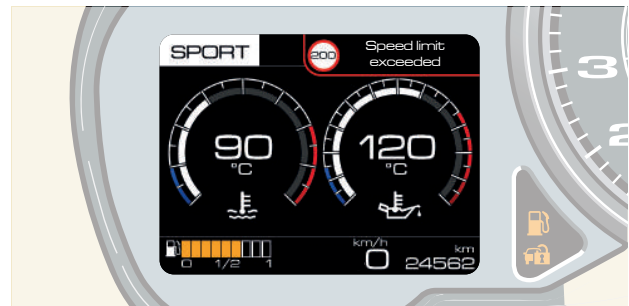
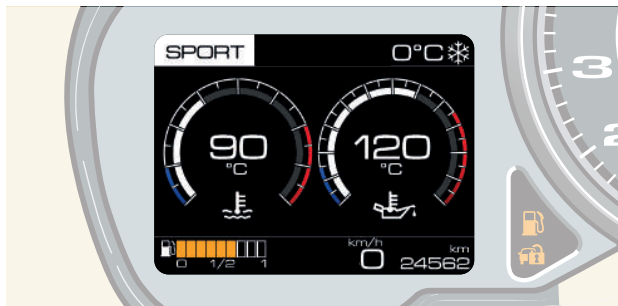



Parking sensors (optional)

To help the driver when parking, the vehicle can be fitted on request with four sensors in the rear bumper (rear parking sensors), or four sensors in the front and rear bumpers (front and rear parking sensors).

Warning



The system will only operate correctly if the sensors on the bumpers are free of mud, dirt, snow or ice.

When approaching obstacles in front of or behind the vehicle, the parking sensors inform the driver of the distance between the vehicle and the obstacle by way of acoustic signals, which become more frequent as the obstacle approaches, and visual signals in area **B** of the left TFT display (see page 85). By supplementing the driver's direct visual information with that provided by the system acoustic signals and visual warnings, potential collisions can be avoided when parking.

Warning



It is the driver, however, who holds full responsibility for parking manoeuvres and other potentially dangerous situations. The system has only been designed as an aid during parking manoeuvres, since it detects obstacles that are outside the driver's range of visibility.

Use of the sensors therefore does not mean that the driver can be less careful and attentive and not watch out for persons and obstacles during parking manoeuvres.

The rear parking sensors are automatically activated when reverse gear is engaged. When the rear sensors are activated, an acoustic signal warns the driver that the system has been activated. If the vehicle is also equipped with front sensors, these can be activated or deactivated by pressing the relative button on the roof panel (see page 131).

“Stop and Go” function

The “Stop & Go” function, available on vehicles with front and rear parking sensors, automatically activates the front sensors when vehicle speed is 10 km/h or below. This system has been designed to assist the driver in certain traffic conditions (e.g. tailbacks) and signals when the minimum distance is reached between the vehicle and the vehicle in front.

To activate or deactivate the system, call up the MENU screen page, select the items “Car setup” and “Parking sensor”, and select “Auto Under 10 km/h”.

Indication of obstacles

The parking sensor system emits acoustic signals as soon as an obstacle is detected which become more frequent as the obstacle approaches. The acoustic signal stops immediately if the distance from the obstacle increases whereas the tone cycle remains constant if the measured distance from the central sensors remains unchanged.

The vehicle symbol and sensor detection zones appear on the left TFT display: these zones indicate which part of the vehicle is approaching an obstacle (if front or rear and if left, right or central) and the distance from the obstacle (maximum, medium or minimum).

3



If an obstacle is detected at maximum distance in the central front part, it will be displayed as shown below (green).

If an obstacle is detected at medium distance in the central front part, it will be displayed as shown below (orange).

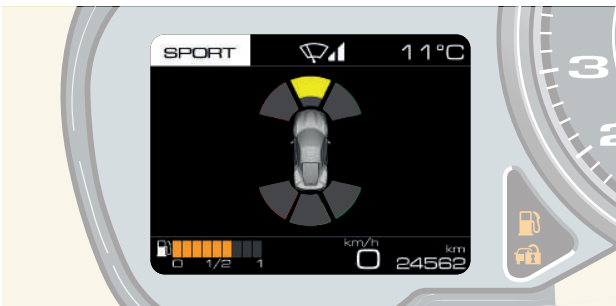

If an obstacle is detected at minimum distance in the central front part, it will be displayed as shown below (red).

The maximum, medium and minimum distances between the vehicle and an obstacle, represented graphically by the colours green, orange and red, are different for the front and rear parking sensors:

Rear sensors:

Maximum distance (green): 80 to 70 cm
(150 to 70 cm in central zone)

Medium distance (orange): 69 to 41 cm

Minimum distance (red): 40 to 0 cm.

Front sensors:

Maximum distance (green): 73 to 53 cm
(110 to 70 cm in central zone)

Medium distance (orange): 52 to 31 cm

Minimum distance (red): 30 to 0 cm.

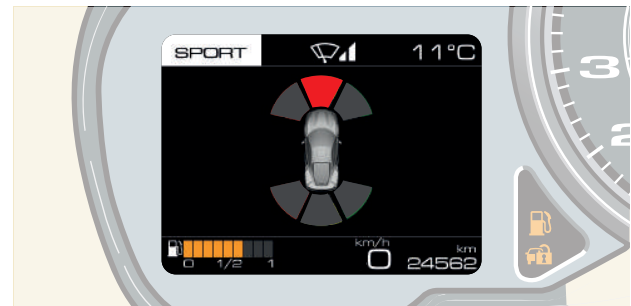



If the front sensors are deactivated or not present, the display does not show the symbols in the front. In the same way, if front sensors are fitted and the rear ones are not activated, the display only shows the symbols in the front. If all the sensors are activated, the system can give several pieces of information at the same time: if an obstacle is detected at a maximum distance in the front central part and at a minimum distance in the rear right part, it will be displayed as shown below.

If the parking sensor system symbols are being displayed and an event occurs that needs to be displayed as an icon and/or special message, the symbol is moved from the centre of the display to the right as shown below.

Cleaning the sensors

When cleaning the sensors, be very careful not to scratch or damage them and avoid using dry, rough or hard cloths. The sensors must be washed with clean water and car shampoo added if necessary. In car washes that use steam jet or high pressure water cleaning equipment, quickly clean the sensors keeping the nozzle at a distance of at least 10 cm. For the repainting of bumpers or retouching the paintwork in the sensor area, contact the FERRARI SERVICE NETWORK. If paint is applied incorrectly, it may prevent the parking sensors from working properly.

3

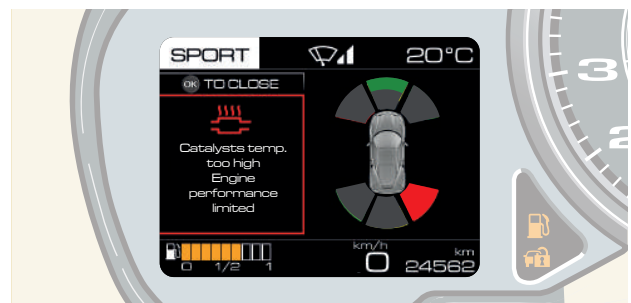
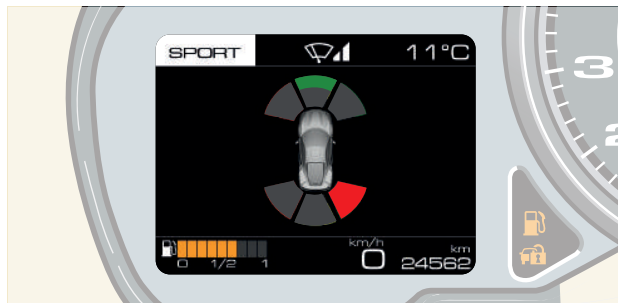



Indication of parking sensor failure

The system ECU checks all the components each time the reverse gear is engaged. If at least one parking sensor is faulty, the special symbol (see page 108) is displayed on the left TFT display together with the message “Parking sensor failure. Warning! Possible obstacles” accompanied by an acoustic signal.

Important note



The sensors are able to detect obstacles with reasonably large, even surfaces (e.g.: poles with diameters of over 60 mm, walls, barriers, trees). Detection is not optimum with obstacles with sharp projections or uneven surfaces.

Important note



During parking manoeuvres, always take the utmost care since obstacles may be located above or below the sensors.

Important note



Objects placed close to the rear part of the vehicle are not always detected by the system and may therefore damage the vehicle or be damaged themselves.

Important note



The signals sent by the sensors may also be affected by damage to the sensors caused by dirt, snow or ice on the sensors or by ultrasound systems (e.g. pneumatic brakes on lorries or pneumatic drills) in the vicinity.

Warning



However, the driver has full responsibility for parking manoeuvres and in other potentially dangerous situations. The system has been designed only as an aid during parking manoeuvres, since it detects obstacles that are outside the driver's range of visibility. The sensors are therefore not a substitute for the driver's care and attention when parking and checking for the presence of persons or objects.



Fault display

Fault visualisation logic

When a fault occurs, the corresponding warning light (if present) comes on on the panel whereas a description of the fault (if available) and the relevant symbol (if available) are displayed on the left TFT display. The message appears on the display at the same time as the warning light (if present) comes on and the main screen page that is displayed at that moment is reduced.

The fault remains on the display for a period of time that varies according to the seriousness of the fault. When the display cycle ends, the symbol remains minimised in area **D** of the display (see page 85) until the cause of malfunctioning has been resolved. In area **B** the main screen page is displayed in “maximum” size.

“ESCAPE” function

If the message “OK TO CLOSE” appears above the fault box, displaying the fault on the screen can be interrupted by pressing and quickly releasing the OK with “ESCAPE” function. When the OK button is pressed, the screen page that was displayed prior to the event reappears.

3

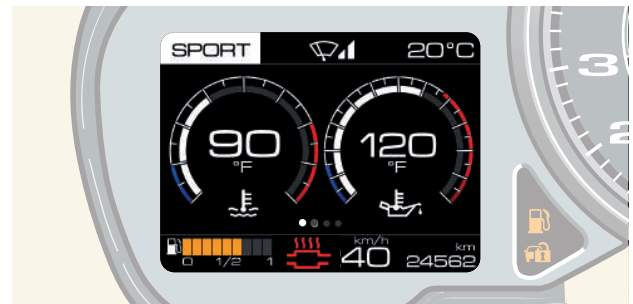
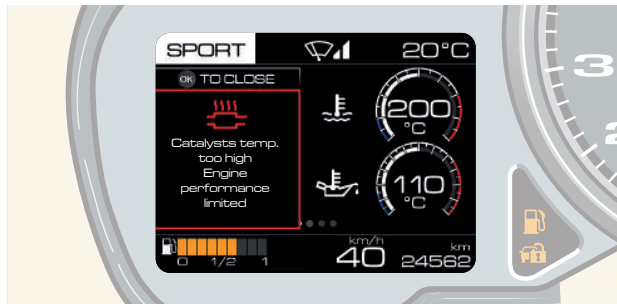



Fault priority levels

The simultaneous display of several faults follows a logic that depends on the priority level assigned to it:

Priority level 0 - Critical fault.

Priority level 1 - Extremely critical fault.

Priority level 2 - Critical fault.

Priority level 3 - Non-critical fault.

When several fault events occur at the same time, faults with priority level 0 are displayed first, followed by priority level 1 and then priority levels 2 and 3. The information on the various faults is displayed in turn for 5 seconds each.

If a fault message is being displayed and a second fault with the same priority level occurs, the latter is only displayed once the first has been displayed for at least 2 seconds. If, on the other hand, a new fault occurs with a higher priority level, this is displayed immediately.

Indication of failure of turn indicators and running lights

A failure of the running lights (front and/or rear) and turn indicators (front and/or rear) is indicated in the same way as other faults but the vehicle symbol with the faulty running light or turn indicator indicated in red is displayed together with a description of the failure instead of the "External lights failure" symbol (see page 105). When the display cycle ends or the **OK** button with "ESCAPE" function has been pressed, the "External lights failure" symbol is minimised.





“Doors, engine or luggage compartment lid open” function display





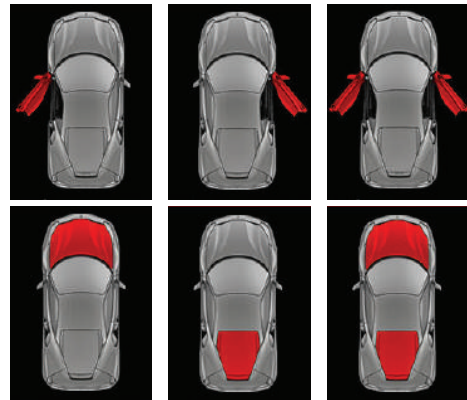
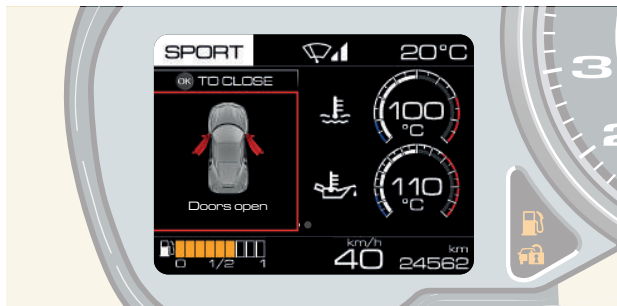

If one or more doors or the engine and/or luggage compartment lid are open, the vehicle symbol appears on the display and indicates which doors or lids are open together with a special message. If the vehicle is in motion, an acoustic signal is also emitted. When the display cycle ends or the **OK** button with “ESCAPE” function has been pressed, the special symbol is minimised (see page 101).

3





List of left hand TFT display symbols and instrument panel warning lamps

TFT	Warning light	Description and warnings
		Alarm system failure Indicates a fault in the alarm system (priority level 1). The system is not programmed (priority level 2). Failure and system not programmed (priority level 1).
		Alarm system failure (priority level 2). Break-in attempted (priority level 2).
		Fuel reserve Indicates that the fuel level is too low (priority level 2).
		Battery conditioner connected When the instrument panel is on, it indicates that the battery conditioner is connected (priority level 0).
		Inertia switch Indicates activation of the inertia switch following an accident and the resulting cut-out of the fuel supply (priority level 0).

The hazard warning lights are also automatically activated.



Alternator failure
If there is a fault in the recharging system (priority level 1).



orange

Low windscreen washer fluid level
Indicates a low level of washer fluid in the windscreen washer tank (priority level 2).



red



Oil temperature
Indicates that the oil temperature is too high (priority level 0).

Turn off the engine and contact the FERRARI SERVICE NETWORK.



orange



Adaptive headlights failure
Symbol and warning light in flashing mode indicate there is a failure in the adaptive headlight system (priority level 2).



orange

Windscreen wiper motor failure
Indicates a windscreen wiper motor failure (priority level 2).



red



Engine coolant temperature
Indicates that the engine coolant temperature is too high (priority level 0).

Turn off the engine and contact the FERRARI SERVICE NETWORK.



red



Oil pressure

red Indicates that the engine oil pressure is too low (priority level 0).

Turn off the engine and contact the FERRARI SERVICE NETWORK.



red

A flashing warning light indicates an engine oil pressure sensor failure (priority level 2).



orange



Engine diagnostic system (EOBD) failure

orange While the engine is running, it indicates a fault in the emission control system and in the ignition/injection system (priority level 0).

Turn off the engine and contact the FERRARI SERVICE NETWORK.

After KEY-ON, it remains on for a self-check for a few seconds after the engine has started.



green

Running lights

green When the running lights or low beams are turned on.



orange

Stop lights failure

Indicates a system failure or blowing of the STOP light bulb (priority level 2).



orange

External lights failure

Indicates a system fault or blowing of a bulb in the running, turn indicator or rear fog lights (priority level 2).



orange

Number plate lights failure

Indicates a system failure or blowing of the number plate light bulb (priority level 2).



orange

Rear fog lights

When the rear fog lights are turned on.



orange

Twilight sensor failure

Indicates a twilight sensor failure (priority level 2).



blue

High beams

When the high beams are turned on.

When the high beams are used to flash.



green

Right turn indicator

When the right turn indicators are activated.



green

Left turn indicator

When the left turn indicators are activated.



green

Hazard warning lights

The left and right hand turn indicator lights flash simultaneously if the hazard warning lights are activated.

3



red

Catalytic converter temperature

Indicates that the catalytic converter temperature is too high: stop the vehicle (priority level 0).

Contact the FERRARI SERVICE NETWORK.



orange

Indicates that the catalytic converter temperature is very high: reduce speed until the symbol goes out (priority level 1).

Indicates a failure of the catalytic converter temperature sensor (priority level 0).



orange

Seat heating

Indicates that heated seat function is enabled (remains displayed for 5 seconds).



orange

Power steering failure

Indicates that the power steering system is inefficient (priority level 2).

Contact the FERRARI SERVICE NETWORK.



green



green

Cruise Control

Indicates that the Cruise Control has been activated/deactivated.



orange



orange

ABS

Indicates an ABS system failure (priority level 1).

The standard braking system is still functioning. Contact the FERRARI SERVICE NETWORK.



orange



orange

ESC off

Symbol and warning light indicate that the ESC system has been deactivated (priority level 1).

The symbol is displayed for 5 seconds together with the "ESC off" message.



orange



orange

ESC system failure

Indicates a fault in the ESC system (priority level 1).

Warning



Stop the vehicle avoiding sharp braking. Stop driving and contact the FERRARI SERVICE NETWORK immediately.

Warning



The vehicle can still be driven at low speed (max. 40 km/h) to clear the road.



orange

ESC system activation (flashing warning light)

Indicates that the ESC system has been activated (priority level 1).



orange

CCM brake discs worn

Indicates that the carbon ceramic brake discs are worn (priority level 2).

Contact the **FERRARI SERVICE NETWORK**.



orange



orange

TPMS

Indicates that one or more tyres have a puncture (priority level 0).

With the warning light in flashing mode for a maximum of 90 seconds after which it remains on in fixed mode, it indicates:

- A failure in the TPMS (priority level 2).
- TPMS temporarily inactive (priority level 2).
- TPMS inactive (priority level 2).
- TPMS not calibrated (priority level 2).



red

Doors/front and rear lids open

The symbol, which is minimised, indicates that one or more doors and/or lids are open.



red



red

Airbag system failure

Indicates a system failure (priority level 0).

With the warning light in flashing mode, it indicates that the airbag test cycle has not been completed (priority level 0).

Contact the **FERRARI SERVICE NETWORK**.



red

Driver-side seat belt not fastened

Indicates that the driver-side seat belt has not been fastened (priority level 0) together with an acoustic signal lasting 90 sec.



red



red

Passenger-side seat belt not fastened

Indicates that the passenger-side seat belt is not fastened (priority level 0).



red

Speed limit exceeded

Indicates that the speed set by the driver has been exceeded (priority level 2), the figure shown indicates the set speed.



orange

E-Diff system failure

Indicates an electronic differential failure (priority level 1).



red



red

Brake malfunction

Indicates that the brake fluid level is low (priority level 0).

Indicates an EPB (electric parking brake) failure (priority level 0).

Indicates an overhaul of the Parking Brake system (priority level 0).

3



red



red



orange

Indicates an EBD system failure (priority level 0).



orange

Rain sensor failure

Indicates a rain sensor failure (priority level 2).



orange

Suspension control system failure

Indicates a malfunction in the suspension control system (priority level 2).

Contact the FERRARI SERVICE NETWORK.



green

Front Lift system status

When on in fixed mode, it indicates that the Front Lift system is activated (vehicle raised).

When on in flashing mode, it indicates that the Front Lift system is being operated (activation or deactivation cycle).



orange

Front Lift system failure

Indicates a Front Lift system failure (priority level 1).



orange

Generic failure

Indicates an airbag warning light failure (priority level 2).

Indicates a Manettino failure (priority level 1).

Indicates a failure in the electronic system (priority level 2).



green

TPMS

Indicates that calibration of the TPMS has been activated.



red



Brake pad wear

Indicates excessive wear of the brake pads (priority level 2).



orange

Parking sensor failure

Indicates that the parking sensor system is faulty (for vehicles equipped with this system) (priority level 2).



orange

DRS fault

Indicates that the DRS active aerodynamic system is faulty.



orange

Key-Less system fault

Indicates that the “Key-Less” key detection system is faulty.



green

Scheduled Maintenance (Service)

Indicates the Scheduled Maintenance deadline.



orange

AVH system

Indicates an AVH system failure (priority level 0).



red

Parking brake

Indicates that the parking brake is applied.



red



red

Gearbox failure

Indicates a system failure (priority level 1).

Contact the **FERRARI SERVICE NETWORK**.



red

Stop&Start failure

Indicates a failure in the Stop&Start system (priority level 0).



Ice hazard

Indicates that the outside temperature is 3 °C (38 °F) or lower, highlighting the risk of icy road surfaces.

Drive carefully in these conditions and slow down since tyre grip is significantly reduced.

Warning



In this condition, activate the "WET" driving mode.



orange

Stop&Start on/Stop&Start system warnings

Together with a special message, it indicates:

Stop&Start system on.

Stop&Start system active

Stop&Start system not available or temporarily deactivated.



orange

Stop&Start off

Indicates that the Stop&Start system has been deactivated.



orange

Stop&Start failure

Indicates a failure in the Stop&Start system (priority level 1).

3



Engine RPM LED on steering wheel (optional)

The five LEDs on the steering wheel rim (available on request) light up in sequence and inform the driver that the maximum engine RPM has been reached for gearshifting. When 5700 RPM is reached, the first LED comes on; the others come on in sequence when 6200, 6700, 7200 and 7700 RPM are reached.

The LEDs on the steering wheel can be deactivated using the MENU screen page on the left TFT display (see page 86): call up the MENU screen page, select the items “Car setup” and “RPM on steer” and then deselect the corresponding item.

Gearbox display

The display which gives information on dual clutch transmission (DCT) is found to the bottom right of the rev counter; with the instrument panel activated, it displays the following information:

- Gear engaged.
- Indication of “Automatic gearbox” mode.
- Indication of “Auto easy exit” mode.
- Indication of gearbox in “Parking” mode.
- Indication of Launch Control activated.
- Indication of AVH system activated.

Important note



Information on the gearbox is useful in all operating conditions.

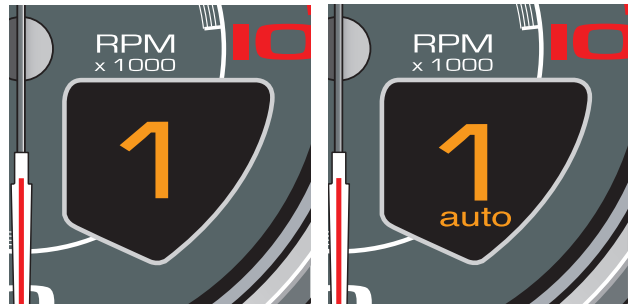
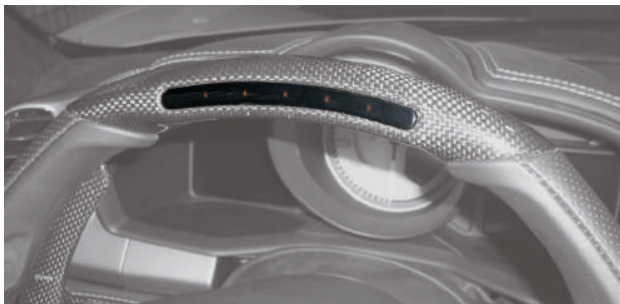



Gear engaged

The gearbox display shows the number or letter indicating the engaged gear in the centre.

- N Neutral
- R Reverse
- 1 1st gear
- 2 2nd gear
- 3 3rd gear
- 4 etc.

When the key is turned to off, the display remains on for at least 3 seconds and displays the engaged gear. If the control panel reads N (Neutral), the letter N is displayed and a buzzer will sound.

Indication of "Automatic gearbox" mode

When the gearbox is used in "automatic" mode (see page 134), the word "auto" appears in the bottom of the gearbox display together with the number or letter indicating the engaged gear.

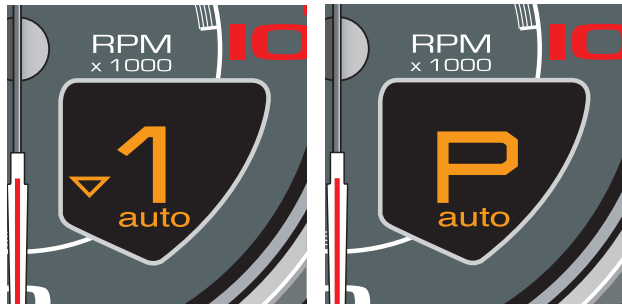

Indication of "Auto easy exit" mode

When the gearbox is used in "Auto easy exit" mode (see page 140), the word "auto" appears in the bottom of the display together with a small "arrow" pointing downwards on the left.

Indication of gearbox in "Parking" mode

When the gearbox is in "Parking" mode, i.e. the Park Lock gearbox locking device is activated (see page 154), the letter "P" appears in the centre of the gearbox display.

Indication of Launch Control activated

When the gearbox is used in "manual" mode and the Launch Control function is requested by pressing the special button on the centre console (see page 155), the word "launch" appears in the bottom of the gearbox display. The word remains while the function is activated. (only available when the driving mode is set to "RACE", "CT OFF", "ESC OFF")

Indication of AVH system activated

In certain circumstances, when the AVH system is activated (see page 153), the word "HOLD" appears in the top of the gearbox display.

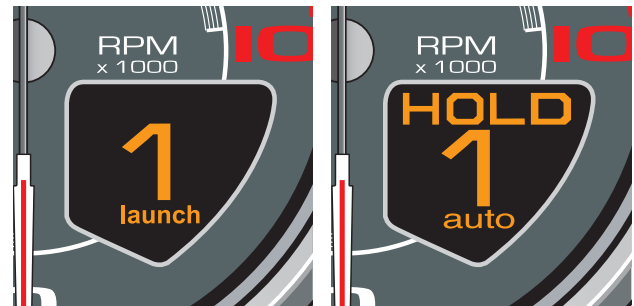

3



Efficient gear shift indicator light (SIL)

With the gearbox in “manual” mode (see page 140) symbol **A** appears when the optimum speed is reached for upshifting. This helps to reduce fuel consumption. If the recommended speed is exceeded or gearshifting takes place, symbol **A** disappears automatically.

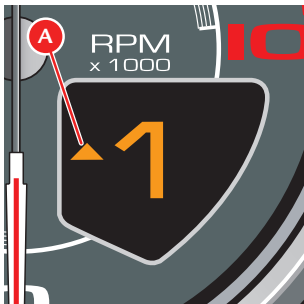

Right TFT display

Located on the instrument panel, it performs the following functions:

- it displays the speedometer;
- it displays infotainment system information;
- it displays the parking camera (if present);
- it displays the FERRARI TELEMETRY system (if present).

The driver can interact with the system by selecting the configuration and setting the parameters using the controls on the dashboard to the right of the steering wheel.

Holding button **A** down switches the infotainment system on and off.

Holding button **B** down allows you to select whether to display infotainment system information or display the speedometer.





USB connectors

The vehicle can be fitted with two USB connectors placed in the centre console pocket change tray.

The first interfaces with the infotainment system and can also be used to recharge a mobile phone or any device with a USB port.

If the vehicle is fitted with the FERRARI TELEMETRY system (optional), there is a second USB connector used to save the telemetry data on the USB support.

Speedometer display

The speedometer can be displayed on the right TFT display in “Speedometer” or “Digital speed” mode.

To select the desired display mode, call up the MENU screen page on the left TFT display (see page 86) and select the items “Display setup”, “Display right”.

“Speedometer” screen page

The “Speedometer” screen page indicates the speed by displaying a virtual analogue speedometer.

3





“Digital speed” screen page

The “Digital speed” screen page indicates the speed in digital form.

Time display

By selecting the special item on the MENU screen page of the left TFT display, you can activate/deactivate the time display in the top right of the “Speedometer” and “Digital speed” screen page.

Parking Camera function (optional)

“Rear Parking Camera” screen (optional)

If the vehicle has a rear parking camera (optional), the “Rear Parking Camera” screen page is automatically displayed on the right TFT display when reverse gear is engaged. This screen page, which continues to be displayed until reverse gear is disengaged, shows the field of vision of the camera mounted on the rear bumper and helps the driver when parking.

With reverse gear engaged, press button **C** on the dashboard to switch between:

- rear view with grids;
- rear view with wide angle lens.

The image is integrated with dynamic parking grids in green, yellow and red which, based on the steering angle, estimate and indicate the vehicle's path to the driver during the manoeuvre.

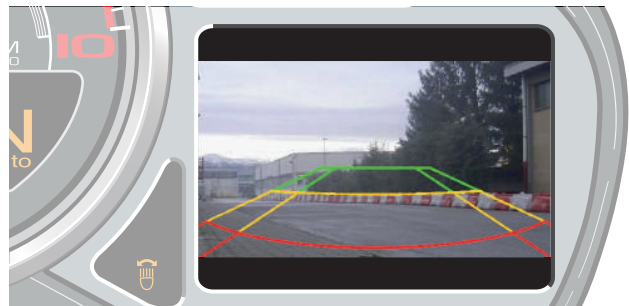
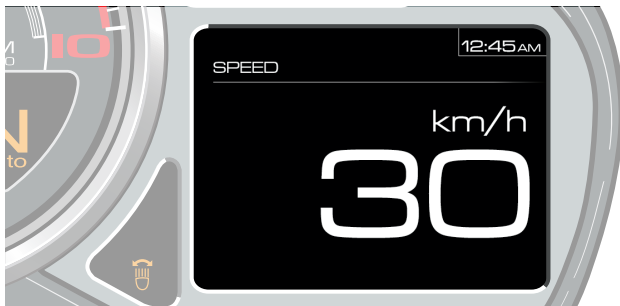



The dynamic parking grids also indicate the distance from any obstacles in the camera's view range: the area within the red grid represents an area that ranges from 0 to 60 cm, the yellow one from 60 to 120 cm and the green one from 120 to 240 cm.

To exit the "Rear Parking Camera" mode, hold down the **C** button for a few seconds or disengage reverse gear if engaged.

"Dual View Camera" screen (optional)

If the vehicle has a "Dual View Camera" system consisting of another camera mounted in the front bumper as well as a rear parking camera, the following views appear on the display:

- front lateral "Corner View";
- central front "Top View";
- rear view with grids (with Rear Parking Camera);
- rear view with wide angle lens (with Rear Parking Camera).

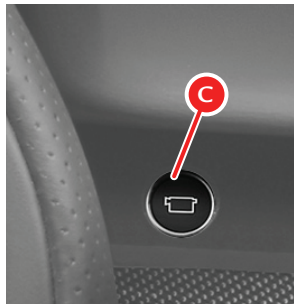

When reverse gear is engaged, the "Rear Parking Camera" screen is automatically displayed on the right TFT display. Without engaging reverse gear, you can switch to the "Corner View" mode (front camera) by pressing and quickly releasing button **C** on the dashboard to the right of the steering wheel.

The view can be selected by pressing button **C**: press and quickly release button **C** to call up the "Corner View". Press the button again to switch from one view to another.

The front camera image display is disabled if the vehicle exceeds a speed of 12 km/h.

To exit the "Dual View Camera" mode, hold down button **C** for a few seconds.

If one of the two rear views is displayed when reverse gear is engaged, the system switches to displaying the "Corner View" screen as soon as reverse gear is disengaged.

3





Cruise Control (optional)

The Cruise Control is an electronic device designed to help the driver drive at a constant speed of over 30 km/h without having to keep the accelerator pedal pressed.

Important note



We recommend only using the Cruise Control on long, dry stretches of road requiring few gear changes (e.g. motorways). Do not use the device for city driving.

Important note



PIT SPEED is a term taken from the motor sports world used by FERRARI to indicate the speed memorised using the device and does not endorse inappropriate behaviour on the road which does not comply with Traffic Regulations.



Activating Cruise Control

To activate the Cruise Control, hold down control **A** for longer than 0.3 seconds.

When the system is activated, a warning lamp lights on the instrument panel (see page 106), and the message “Cruise Control ON”, together with the specific symbol, are shown for 5 seconds on the left hand TFT display.

The Cruise Control can only be activated with the 4th, 5th, 6th or 7th gear engaged.

When going down slopes with the device on, the vehicle speed may be slightly higher than the memorised speed.

Memorising the speed

Proceed as follows:

- with the device activated, bring the vehicle to the desired speed by pressing the accelerator pedal;
- turn control **A** clockwise (+) for at least 3 seconds and then release it: the speed of the vehicle is memorised and you can release the accelerator pedal.

If necessary, you can accelerate by pressing the accelerator pedal: when the pedal is released, the vehicle will return to the previously memorised speed.

Resetting the memorised speed

If the device has been turned off by pressing the brake pedal, the memorised speed can be reset as follows:

- gradually accelerate until the vehicle reaches a speed which is close to the memorised speed;
- quickly press control **A**.



Increasing the memorised speed

This can be done in two ways: by pressing the accelerator and memorising the new speed reached or by turning control **A** clockwise (+).

One turn of the control corresponds to an increase in speed of about 2 km/h; if the control is kept turned on the other hand, the speed continually increases.

Reducing the memorised speed

This can be done in two ways: by deactivating the device and then memorising the new speed or by turning control **A** counterclockwise (-).

One turn of the control corresponds to a decrease in speed of about 2 km/h; if the control is kept turned on the other hand, the speed continually decreases.

Deactivating Cruise Control

Hold down button **A** (for longer than 0.3 seconds). The device is also automatically deactivated by pressing the brake pedal.

When it is deactivated, the warning light on the instrument panel goes out and a "Cruise Control OFF" message accompanied by a special symbol appears on the left TFT display for 5 seconds.

Warning



While driving with the Cruise Control activated, do not put the vehicle into "N" (neutral).

Warning



If the Cruise Control is malfunctioning or faulty, deactivate the device and contact the FERRARI SERVICE NETWORK.

3



Controls on the steering wheel

Start button

By pressing the ENGINE START/STOP button **A** after “KEY-ON” (the vehicle system comes on), the engine starts when it is pressed again and the brake pedal is held down. When the engine has started, release the ENGINE START/STOP button.

Do not hold the ENGINE START/STOP button down for a long time.

For more information on starting the engine, see page 135.

Driving mode control switch “Manettino”

The driver can select the desired driving mode by using the “Manettino” **B**.

The driving mode selected does not exempt the driver from complying with the rules of safe driving.

Important note



In the event of a failure of one of the onboard systems, signalled by the special symbol on the left TFT display, the Manettino” moves to a “recovery” position, but still allows the vehicle to be driven. In these cases, contact the FERRARI SERVICE NETWORK.

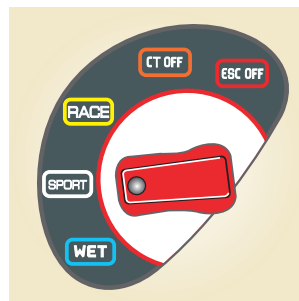



Driving modes that can be selected with “Manettino”

WET mode

This is the maximum safety driving mode. Recommended in low grip conditions.

SPORT mode

This is the ideal setting for vehicle performance recommended for everyday driving.

RACE mode

This mode offers maximum performance and stability in high grip conditions and is particularly suitable when using the vehicle on track.

CT OFF mode

When this mode is selected, the F1-Trac traction control system is disabled whereas stability control remains active. This setting is used on the racing track.

ESC OFF mode

This mode allows the driver complete freedom and control of the vehicle for track use. No electronic system other than the E-Diff controls vehicle stability.

For further information on the driving modes that can be selected, refer to the paragraph “Driving using the driving mode control switch” on page 146.

3

Warning



In low- to medium-grip conditions (e.g. wet, icy, sandy roads), do not deactivate the **ESC** system.



Active aerodynamics (DRS)

The 3 active rear flaps (DRS) are electrically operated by way of sensors and a specific algorithm. The two possible configurations are:

- Flaps raised, close to the vehicle: high downforce, the air flow is kept close to the diffuser and guarantees better grip.
- Flaps lowered: the flaps are lowered stalling the diffuser and reducing drag.

Important note



The active aerodynamics are disabled when the external temperature is below 3 °C.

The DRS icon at the top of the left hand TFT display indicates the state of the active aerodynamics system (DRS).

When the system is active, the icon shows an extended flap in black.

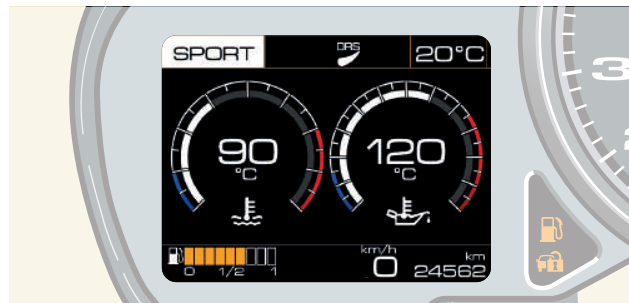



If the ECU identifies a system fault impeding DRS activation, the following pop-up is shown on the display:

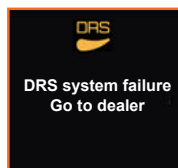

After 20 seconds, the pop-up is reduced to an icon at the bottom of the display, and the fault is indicated by the DRS icon displayed in orange.



If the fault involves the electronic control system, the following pop-up is displayed:



After 20 seconds, the pop-up is reduced to an icon at the bottom of the display, and the fault is indicated by the warning icon displayed in orange.



Side Slip angle Control (SSC2)

In RACE and CT OFF manettino modes, the electronic slip angle control system (Side Slip angle Control - SSC) ensures the maximum grip possible in relation to the driving conditions.

The system uses specific sensors and an algorithm to determine lateral acceleration, yaw angle, steering wheel angle and speed. The SSC system analyses the vehicle slip angle in real time and compares it against ideal reference values to optimise engine torque delivery (through the F1-Trac traction control system, see page 63) and more effectively distribute the torque transmitted through the differential across the two drive wheels (via the E-Diff electronic differential, see page 63). The system also includes active damping control of the shock absorbers which makes vehicle behaviour smoother and more uniform when the software intervenes.

3



Suspension damping delink button

By pressing button **C** on the left of the steering wheel, the driver can choose to separate the suspension damping control from the logic of the “Manettino” driving mode control switch.

For further information, see page 150.

Horn control

The horn sounds when you press on the horn symbol on the steering wheel rim.





“UP” shift paddle

Pull the right-hand **UP** paddle towards the steering wheel to shift gears up.

“DOWN” shift paddle

Pull the left-hand **DOWN** paddle towards the steering wheel to shift gears down.



Windscreen washer/wiper stalk

Important note



The windscreen wipers and washer only work when the instrument panel is activated.

The windscreen wipers and washer are operated using lever **A** on the steering wheel: the lever must be pressed towards the dashboard or pulled back according to the function you require.

The windscreen wipers have 4 different speeds:

OFF Windscreen wipers stationary.

AUTO The rain sensor adjusts the windscreen wiper timing to the intensity of the rain.

- 1 Slow continuous operation.
- 2 Fast continuous operation.

3





With the wipers stationary (**OFF**), quickly pressing lever **A** towards the dashboard activates the windscreen wipers in **AUTO** speed.

With the wipers on, quickly pressing the lever towards the dashboard increases windscreen wiper speed (from **AUTO** to **1**, from **1** to **2**).

With the wipers set to **AUTO** or **OFF**, holding the lever towards the dashboard activates maximum speed (**2**). With speed **1** or **2**, on the other hand, the windscreen wipers stop.

With the wipers on, quickly pulling lever **A** back decreases windscreen wipers speed (from **2** to **1**, from **1** to **AUTO**, from **AUTO** to **OFF**).

With the wipers stationary, quickly pulling the lever back activates fast temporary operating of the wipers (antipanic wiping).

The windscreen wiper speed is indicated in the top of the left TFT display as shown in the figure below.

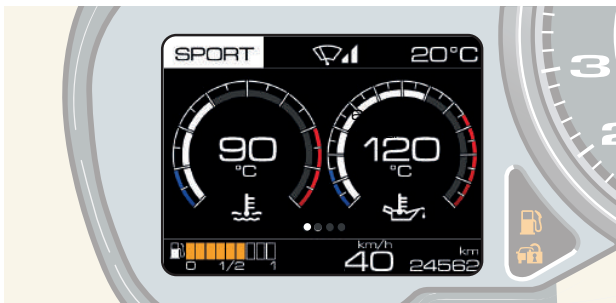

Important note



Windscreen wiper operating is always guaranteed even if there is an electronic system failure. If there is a failure, the windscreen wipers can be activated by pressing lever **A** and deactivated by pulling it back.

If there is a particularly serious failure, operating may not be automatically maintained: if this is the case, the windscreen wipers can be kept activated by holding down lever **A**.

Windscreen washer

To activate the windscreen washer, keep lever **A** pulled. When the lever is released, the windscreen wiper returns to the preset speed.

Warning



Do not start the windscreen washer during the cold months until the windscreen has warmed up. If it has not warmed up, the liquid could freeze on the glass and interfere with visibility.

Headlight washer

The headlight washer is activated automatically when the windscreen washer is operated and the low beams are on. The headlight washer and windscreen washer share the same fluid tank and a low fluid level is indicated by the relative symbol on the left TFT display.



Rain sensor

The rain sensor automatically adjusts the windscreen wiper timing to the intensity of the rain. The system is activated by moving the windscreen wiper to **AUTO**.

When operating automatically, the wiper speed ranges from a minimum intermittent setting (one wipe every 5 seconds approx.) when the windscreen is damp to fast continuous operation in heavy rain.

Important note



The rain sensor function is deactivated when the instrument panel is switched off by leaving the windscreen wiper in **AUTO** position. To reactivate the system at the next KEY-ON, set the wipers to **AUTO** by quickly pressing lever A towards the dashboard.

Warning



Before cleaning the front windscreen (for example in service stations) make sure the rain sensor is deactivated or that the instrument panel has been switched off. The rain sensor must be deactivated also when washing the vehicle by hand or in automatic car washes.

In case of ice or snow on the front windscreen, do not activate the rain sensor to avoid damaging the wiper motor and/or blades.

Rain sensor failure

If there is a rain sensor failure, indicated by a special symbol on the left TFT display (see page 108) while the windscreen wiper is set to **AUTO**, the wipers will be set to intermittent operation with one wipe every 1 second approximately. If this is the case, we recommend that you deactivate the rain sensor and turn on the wipers, if necessary, in continuous mode.

Important note



If this occurs, contact the **FERRARI SERVICE NETWORK** as soon as possible.

3





Lighting

The external lights and turn indicators only work when the instrument panel has been switched on.

The external lights can be switched on and off manually or automatically, depending on the ambient light.

Light switch

Switch **A**, on the dashboard to the left of the steering wheel, can be set to four different positions:

- 0** Day lights on.
-  Low beams on (*).
- AUT** Automatic switching on and adjustment of the external lights according to ambient light.
-  Parking lights.

(*) The relative warning light on the instrument panel comes on.



High beams

To turn on the high beams when the light switch **A** is set to , push lever **B** on the steering wheel towards the dashboard.

When the high beams are on, the relative warning light  on the instrument panel comes on.

Then push lever **B** towards the dashboard or pull it back to turn off the high beams and turn on the low beams.

Flashing the headlights

The headlights can be flashed by pulling back the left-hand lever **B**.

Flashing also occurs with lights off if the instrument panel is switched on.

The high beams are used for flashing.





Important note



Follow the Road Regulations of the country you are travelling in for using the high beams.

Parking lights

The parking lights only work when the instrument panel is switched off.

They are activated by turning the light switch **A** to position $P \leq$.

When the parking lights are on, the warning light illuminates on the instrument panel $\Rightarrow \Leftarrow$.

When the parking lights are on, press and hold one of the two turn indicator buttons **C** on the steering wheel (see page 128) for more than 0.5 seconds to turn on the single-side parking lights on the corresponding side; press the same turn indicator again for more than 0.5 seconds to go back to full parking lights.

When the partial parking lights are on (on only one side of the vehicle), the running light warning light $\Rightarrow \Leftarrow$ turns off whereas the vehicle symbol indicating which parking light is on (left or right) is displayed on the left TFT display for 10 seconds.

When the light switch **A** is turned to **AUT** and the instrument panel is activated, the low beams and number plate lights turn on and off automatically according to the ambient light.

Important note



The high beams can only be activated manually by pulling back the left-hand lever **B**.

Important note



If the high beam control is activated, the high beams will turn on every time the lights are activated automatically. We recommend therefore that you turn them off every time the twilight sensor deactivates the external lights.

Warning



If there is fog during the day, low beams will not be turned on automatically. The driver must always be ready to turn on the lights manually and also the rear fog lights, if necessary.

Important note



After automatic activation of the external lights, it will always be possible to turn on the rear fog lights manually. When the external lights are deactivated automatically, the rear fog lights are also turned off (if active) automatically. Therefore, if necessary, the driver will have to turn on the rear fog lights manually upon the next automatic activation.

3



Warning



The driver is always responsible for turning on the external lights, depending on the ambient light and in compliance with the regulations in force in the country of use. The automatic system for turning on and off the external lights must be considered an aid for the driver. If necessary, turn the lights on and off manually.

Twilight sensor

The twilight sensor is comprised of a global sensor which measures the ambient light upwards.

In the event of sensor failure, the system switches on the low beams regardless of the daylight conditions; a failure message will appear on the instrument panel display.

The failure indication will be displayed as long as the light switch is turned to AUT.

If this occurs, we recommend that you deactivate the automatic system and turn on the external lights manually if necessary.

Important note





If this occurs, contact the FERRARI SERVICE NETWORK as soon as possible.

Day lights

The LEDs on the headlights serve as front turn indicators and day lights.

Turn indicators

Quickly press the left indicator or right indicator button **C** on the steering wheel to switch on the relevant turn indicator.

The relative warning light  or  on the instrument panel comes on.

The turn indicator goes off when the steering wheel is realigned.

Holding down one of the two **C** buttons (for more than 0.3 seconds) temporarily switches on the relevant turn indicator: it is switched off after 3 flashes ("lane change" function).





Rear fog lights

The rear fog lights are turned on only if the high beams or low beams are on when button **D** is pressed; the relevant warning light **E** on the instrument panel comes on to indicate that they have been turned on.

Important note



Use the rear fog lights only in poor visibility conditions.

Hazard warning lights

Press button **F** to turn on the hazard warning lights. All the turn indicators will start blinking intermittently; this function is also available when the instrument panel is switched off. When the lights are on, the relative warning lights on the instrument panel and the button flash.

To turn them off, press the button again.

3

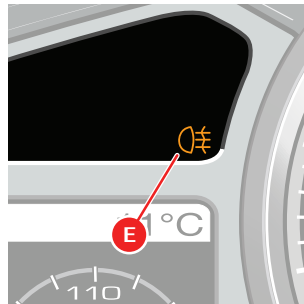



“Follow me home” function

With the “Follow me home” function, the low beams stay lit for a preset period of time once the engine has been turned off and light up the area around the vehicle to help the driver and passengers see their way in the dark.

To activate this function manually, push the high beam/flash stalk **B** (see page 126) with the instrument panel switched off, within 3 minutes of switching off the engine (this time is reduced to 30 seconds if the driver side door is opened). Each time lever **B** is pressed, the period of time that the low beams remain on increases by 30 seconds up to a maximum of 210 seconds.

Each time lever **B** is pressed, the message “Follow me” appears on the left TFT display followed by the preset period of time that the low beams remain on.

AFS adaptive headlights (optional)

The AFS adaptive headlight system (available on request) enables synchronous movement of the left and right front beams (high and low) and has been designed to illuminate the road better and reduce areas of shadow in the vehicle's trajectory.

The headlights' swivel angle, which ranges from 8° inwards and 15° outwards, is defined by the steering angle.

The AFS system also uses a “Dynamic Levelling” device that directs the light beam vertically when accelerating and braking by moving the headlights up to 1.9° upwards when braking and up to 1° downwards when accelerating.

The adaptive headlight system deactivates its corrective action when driving round bends at low speed.



Dome light

When the doors are closed, the dome light **D** on the roof can be turned on or off using the switch **E**.

Switches **F** and **G** turn the driver-side and passenger-side spotlights on and off.

The dome light activates automatically in the following conditions:

- when a door is opened, for approx. 3 minutes;
- when all the doors are closed with the instrument panel deactivated, for approximately 10 seconds;
- when the doors are unlocked, for approx. 10 seconds;
- when the inertia switch is activated, for approx. 15 minutes.

The dome light deactivates automatically in the following conditions:

- after the preset activation time expires;
- when the doors are closed and the instrument panel is activated;
- when the doors are locked;
- when the inertia switch is reactivated.

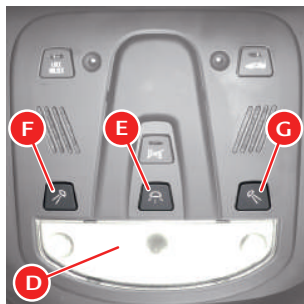

Roof panel controls

Door lock/unlock

Both doors can be locked by activating/deactivating the “LOCK/UNLOCK” **H** button. For further information, see page 74.

Deactivating the anti-lift alarm

Press button **L** to deactivate the anti-lift alarm system. For further information, see page 18.

Front parking sensors (optional)

On vehicles fitted with front and rear parking sensors, the front parking sensors are activated/deactivated by pressing button **M**. When the front parking sensors are activated, the light on the button comes on.



3



Driving the vehicle

Running-in

The latest manufacturing techniques have allowed us to achieve high precision and accuracy levels in the construction and assembly of components. Nonetheless, the vehicle movable parts undergo a settling process, basically during the first hours of operation.

Engine and transmission

Avoid exceeding 5,000 RPM for the first 1,000 km (620 mi).

After starting, do not exceed 4,000 RPM until the engine has warmed up (oil temperature: 65-70 °C / 149-158 °F).

Do not let the engine run at a constantly high speed for a prolonged time.

Warning



BEFORE YOU DRIVE

Check that the seat belts are fastened.

Check that the doors are closed.

Check that the seat is properly adjusted.

Check the rear-view mirror adjustment (central and sides).

Before a trip

Preliminary checks

Check the following at regular intervals and always before long trips:

- tyre pressure and condition;
- levels of fluids and lubricants;
- condition of the windscreen wiper blades;
- proper functioning of the warning lights and external lights.

Important note



In any case, it is advisable to perform these checks at least every 1000 km (620 mi) and always comply with the maintenance schedule.

It is also advisable to:

- clean the glass covers of the external lights and all the glass surfaces;
- properly adjust the mirrors, steering wheel, seats and seat belts.

Refilling

Warning



Use unleaded fuel only!

Using leaded fuel would permanently damage the catalytic converters.

For specifications and quantities of lubricants and fluids, refer to the "Refilling" table on page 38.



Starting and driving the vehicle

System start-up

When the instrument panel is activated (KEY-ON, see page 135) both the TFT displays on the instrument panel are activated and system diagnosis is performed. During diagnosis, which lasts 5 seconds, a check is performed on the warning lights on the panel and the presence of any faults is checked.

If diagnosis detects any errors, they are only displayed once the 5 seconds required for the check have elapsed. The cases listed below are an exception and errors are displayed as soon as the key is turned to on, even during diagnosis:

- Low engine oil pressure (see page 105).
- Inertia switch triggered (see page 104).
- Semi-automatic gearbox safety warnings.
- Deactivation of EPB warning (see page 152).

If the next scheduled maintenance deadline is approaching, each time the key is turned to on, information on scheduled maintenance is automatically displayed after diagnosis. For further information, refer to the "Maintenance Schedule" paragraph on page 238.

Finally, each time the key is turned to on, the message for activation of the alarm when an intrusion has been attempted (see page 19) is also displayed (after diagnosis).

Once the system check has been completed, the gearbox display is activated and the letter "P" (Parking) or "N" (Neutral) will be displayed.

Important note



BEFORE YOU DRIVE

If the warning light **A** does not turn off after diagnosis, indicating a fault in the gearbox (which is also indicated by the symbol and specific message on the left TFT display - see page 108), contact the **FERRARI SERVICE NETWORK**.

3

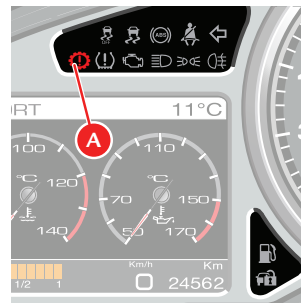



Important note



The vehicle is equipped with an electro-hydraulically controlled gearbox system operated by means of paddles on the steering wheel.

The default setting for the DCT gearbox is always “Automatic” mode (see page 140).

Every time the vehicle is started, the DCT gearbox is in “Auto easy exit” mode (see page 140) unless the vehicle was in “Automatic” mode when the engine was turned off.

To exit the “Auto easy exit” mode operate the **UP** and **DOWN** paddles (while the vehicle is moving) or press the **AUTO** button on the centre console.

Important note



Immediately release the **UP** and **DOWN** paddles or button **R** after the gearbox display shows that the gear has been engaged; a prolonged manoeuvre would cause the gearbox failure warning light to turn on (see page 108) and triggering of the buzzer.

Important note



None of the gears can be engaged if the luggage compartment lid is open or not properly closed. When the vehicle is stationary, with the driver-side door open or not properly closed and the brake pedal released, the system disengages the gear engaged after approximately two seconds.





“Key-Less” ignition system

The new FERRARI keys use a Key-Less vehicle ignition system which can switch on the instrument panel and then the engine by simply placing the key inside the vehicle, near the driving area. The dedicated ECU recognises the vehicle key by the electronic ID code it contains. The ENGINE START/STOP key on the steering wheel controls KEY-ON, KEY-OFF, ENGINE START and ENGINE STOP.

- **KEY-ON**, to activate the vehicle system (instrument panel, air conditioning and heating system, infotainment system, etc.), press and quickly release the ENGINE START/STOP button on the steering wheel.
- **KEY-OFF**, to deactivate the vehicle system without starting the engine, press the ENGINE START/STOP button on the steering wheel again.
- **ENGINE START**, to start the engine, keep the brake pedal pressed and press the ENGINE START/STOP button on the steering wheel.



Warning



Hold the brake pedal down while starting the engine.

- **ENGINE STOP**, to switch off the engine when the vehicle is stationary, press the ENGINE START/STOP button on the steering wheel.

If the vehicle is in motion and the engine has to be switched off, press the ENGINE START/STOP button and hold it down for at least 2 seconds (alternatively, press the button quickly 3 times in succession).

If the key battery has a charge level that is only just sufficient, the vehicle informs the driver via a message on the left TFT display of the instrument panel and recommends replacing the battery as soon as possible. If the battery is flat or the key is not recognised, perform the emergency engine stop procedure described on page 204.

3

Warning



If the door closing button on the key is pressed when inside the vehicle, the engine start function is disabled. The door opening command must be given to deactivate the alarm and, in this way, the engine can be restarted. This occurs even if the door closing command is given from a key outside the vehicle when there is a second key inside the vehicle. The engine start function on the second key (inside the vehicle) is disabled. By issuing the door opening command on any registered key, the engine start function is reset.



If the engine fails to start after several attempts, check for one of the following causes:

- insufficient speed of the starter motor (flat battery);
- ignition device faulty;
- electrical contacts faulty;
- fuel pump fuses blown.

Warming up the engine

Do not run the engine at high speed until the engine oil temperature has reached at least 65-70 °C (149-158 °F), approximately.



Starting the vehicle

With the engine started, the vehicle stationary and the brake pedal pressed, pull the right-hand “UP” paddle towards the steering wheel to engage 1st gear.

Release the brake pedal and press the accelerator to start off.

With the engine running and the vehicle stationary, you can change directly from 1st gear to “R” (reverse) by pressing the **R** button on the centre console and from reverse to 1st by moving the **UP** paddle.

Warning



If the **UP** and **DOWN** paddles are not working, the message “Depress brake pedal and press LAUNCH to engage gear” will appear on the left TFT display; you can therefore engage the gear by pressing the **LAUNCH** button on the centre console (see page 155) and the brake pedal.

In these cases, the “Launch Control” function is not available.

If the engaged gear was **R**, the **LAUNCH** button must be pressed twice to engage 1st gear.



Important note



When reverse is selected, an acoustic safety signal beeps intermittently as long as “R” is engaged.

During prolonged stops with the engine running, it is advisable to keep the gearshift in “N”.

Important note



If you allow the vehicle to move forward in N, when UP or DOWN is requested, a gear will be engaged that corresponds to the speed of the vehicle.

3



UP-shifting

Use the right-hand **UP** paddle without releasing the accelerator pedal.

An **UP**-shift request is not accepted when engagement of the requested gear forces the engine to underrev or if an **UP**-shift is already in progress because of engine overrevving.

In any event, it is advisable to:

- Shift gears without releasing the accelerator pedal if pressed.
- Wait until gearshifting has been completed before requesting the next shift, avoiding a rapid sequence of multiple requests.

UP-shifting due to overrevving

The system “automatically” engages a higher gear if the accelerator pedal is pressed and the engine approaches the “runaway speed rate” (overrevving).

Important note



This will not occur when the system is in “SPORT”, “RACE”, “CT OFF” and “ESC OFF” driving modes.

DOWN-shifting

Use the left-hand **DOWN** paddle without releasing the accelerator pedal.

A **DOWN**-shift request is not accepted if engagement of the requested gear forces the engine beyond a certain RPM, depending on the gear requested, or if a **DOWN**-shift is already in progress because of engine underrevving.

In any event, it is advisable to:

- Shift gears without releasing the accelerator pedal if pressed.
- If **DOWN**-shifting is requested to start overtaking which requires quick acceleration, press the accelerator pedal just before using the paddle.
- Wait until gearshifting has been completed before requesting the next shift, avoiding a rapid sequence of multiple requests.

DOWN-shifting due to underrevving

- The system shifts down “automatically” if the engine goes below a minimum number of revs (1250 RPM).
- The **DOWN**-shift request from the paddle is ignored if gearshifting is already in progress due to engine underrevving.

Sequential downshifting

During deceleration, with the brake pedal pressed and the ABS system disabled, sequential downshifting can be performed by holding the left-hand “**DOWN**” paddle down.

The sequential gearshifting request is accepted until the second gear is engaged.

“N” (Neutral) request

With the engine running, pull both **UP** and **DOWN** paddles towards the steering wheel at the same time without pressing the brake pedal to request neutral “N”.



If necessary, “N” can be requested at any speed. Subsequently, if an “UP” or “DOWN” shift is requested, the system will engage the gear most suited to the speed of the vehicle.

For information on the Park Lock, see page 154.

Stopping the vehicle

When the vehicle stops, the system automatically engages 1st gear unless Neutral has already been requested.

When the vehicle is stationary and the engine is running, hold the brake pedal down until ready to move off again.

Switching off the engine

The engine can be switched off with the gearbox either in “N” or with a gear engaged.

After switching off the engine (**ENGINE STOP**, see page 140), the gearbox display remains on for a few seconds and indicates which gear is engaged. If the gearbox is in “N” a buzzer will sound. Before switching off, the letter “P” is displayed on the gearbox display to inform the driver that the Park Lock has been activated.

Warning



Never leave the vehicle with the gearbox in “N”. Always make sure that the letter “P” (Parking) appears on the gearbox display.

Warning



Never leave the vehicle with the engine running.



“Automatic gearbox” mode

The “Automatic gearbox” mode is enabled/disabled by pressing the **AUTO C** button on the centre console. When the “Automatic” mode is enabled, the word “auto” appears on the gearbox display. To exit the “Automatic” mode, you must press the **AUTO** button until the word “auto” on the gearbox display disappears.

When the “Automatic Gearbox” mode is enabled, the system will automatically UP-shift and DOWN-shift according to vehicle speed, engine revs and the torque/power request of the driver.

When you are in “Automatic” mode, you can however manually shift gears using the **UP** and **DOWN** paddles. The system remains in “Automatic” mode: this is indicated by the word “auto” that remains on the gearbox display in flashing mode when the paddles are used.

When the vehicle is stationary, a “N”, 1st gear or “R” request will not result in a change from “Automatic” to “Manual”.



“Auto easy exit” mode

Every time the vehicle is started, the gearbox starts in “Auto easy exit” mode unless it was in “Automatic” mode when the engine was turned off. In this case, it remains in “Automatic” mode the next time the engine is started.

Activation is signalled by the word “auto” and an arrow ▼ in the gearbox display.

In this mode, the system will automatically UP-shift and DOWN-shift according to vehicle speed, engine revs and the torque/power request of the driver.

To exit the “Auto easy exit” mode and go to “Manual” mode, operate the **UP** or **DOWN** paddle (while the vehicle is moving) or press the **AUTO** button on the centre console.

If the “Automatic” gearbox mode is then requested by pressing the **AUTO** button, the system will apply all the characteristics of the “Automatic” gearbox mode.

Push start

Warning



Push starting is not allowed.



Safe driving

For safe driving, it is essential that the driver be aware of the best driving techniques suited to various circumstances. Always try to prevent dangerous situations by driving with caution.

Before you drive

- Adjust the position of the seat, steering wheel and rear-view mirrors, in order to obtain the best driving position.
- Adjust the backrest so that your chest is upright and your head is as close to the headrest as possible.
- Ensure that nothing (e.g. mat covers, etc.) is blocking the pedals.
- Check that the lights and headlights are working properly.
- Ensure that any child restraint systems (e.g. child seats, cradles etc.) are properly fixed on the passenger seat.
- Your reflexes are quicker if you eat lightly before driving: avoid heavy meals before a trip.
- Do not drink alcoholic drinks before and during the journey.

At regular intervals, check the following:

- Tyre pressure and condition.
- Engine oil level.
- Engine coolant level and system condition.
- Brake fluid level.
- Steering fluid level.
- Windscreen washer fluid level.

While travelling

- Caution is the number one rule for safe driving, which also means you should take other people's behaviour into consideration.
- Follow the Road Regulations in force in the country you are driving in and always respect the speed limit.
- Always make sure that the driver and passengers have their seat belts fastened and that all children are travelling in suitable child seats.
- Good personal physical conditions ensure you can drive long distances safely.

Warning



Driving under the influence of drugs, some medicines and alcohol is dangerous to yourself and others as well as contravening road regulations and legal norms.

Travelling without your seat belt fastened increases the risk of serious injury and death in the event of a collision. Always fasten seat belts and use child seats, if present.

Do not travel with objects lying on the floor, especially in front of the driver's seat: in the event of braking, these could slide under the pedals, making it impossible to brake or accelerate.

Additionally, ensure that any loose floor mats sit correctly.

Water, ice and salt spread on icy roads may deposit on the brake discs and reduce the efficiency of the initial braking.

3



- Make regular stops to loosen up your limbs and refresh yourself and avoid driving for hours on end.
- Keep a constant air circulation in the passenger compartment.
- Never coast downhill with the engine off: in these conditions the engine brake, servo brake and power steering are inefficient, braking requires greater pressure on the pedal and steering will be harder.

Driving at night

When you are travelling at night, follow these fundamental rules:

- Reduce speed, particularly on dark roads.
- Drive with due caution in consideration of the reduced visibility.
- If you start feeling tired or sleepy, stop immediately: to continue driving would be a risk for yourself and for others. Continue only after you have had a rest.
- At night, it is difficult to judge the speed of vehicles in front of you as you can only see their taillights: keep at a greater safety distance than you would during the day.
- Use the high beams only outside of urban areas and when you are sure that they will not disturb other drivers.
- Turn off the high beams when you see oncoming vehicles and use the low beams.
- Keep the lights and headlights clean.
- Watch out for animals crossing the road when travelling outside urban areas.

Driving in the rain

Rain and wet roads can cause hazardous situations.

Warning



Given the vehicle's reduced ground clearance, a characteristic that guarantees exceptional aerodynamic performance and driving comfort, in adverse weather conditions we recommended driving through standing water or floods as slowly as possible. This recommendation should be observed to prevent water entering the intake ducts and causing irreparable damage to the engine.

All manoeuvres are more difficult on a wet road since tyres have significantly less grip on the road. This means that the braking distances increase considerably and road-holding decreases.

Here is some advice for driving in the rain:

- Keep a greater safety distance between yourself and the other vehicles and reduce your speed.
- When it is raining very hard, visibility is also reduced. In these cases, to make yourself more visible to others, turn on the low beams even during the day.
- Drive through puddles at low speed to avoid losing control of the vehicle ("aquaplaning"); if this occurs, grip the steering wheel firmly.



Warning



If the road is wet, reduce your speed to avoid “aquaplaning” (when the tyre no longer touches the road surface because the side channels of the tyre tread are not capable of removing all the channelled water due to their particular shape or insufficient depth and a layer of water is placed between the road surface and the tyre. The fluid pressure generated is so high that it supports the vehicle's weight making it virtually impossible for the driver to control the vehicle).

- Use the ventilation system to demist the windscreen (see page 176) and avoid visibility problems.
- Periodically check the condition of the windscreen wiper blades.

Driving in fog

Whenever possible, avoid travelling if there is thick fog. If you have to drive in misty conditions, or if there is thick fog or fog banks, follow these rules:

- Keep a moderate speed.
- Turn on the low beams, also during the day, and use the rear fog light. Avoid using the high beams.

Warning



On stretches where visibility is good, turn off the rear fog light, it may be annoying for the occupants of the vehicles behind you.

- Remember that fog makes the road damp and therefore all manoeuvres are more difficult and braking distances are longer.
- Keep a safe distance from the vehicle in front of you.
- As far as possible, avoid suddenly changing speed and direction.
- As far as possible, avoid overtaking.
- In the event of an emergency stop, (e.g. failures, inability to proceed due to poor visibility conditions, etc.) try to free the main driving lane. Then turn on the hazard warning lights and, if possible, the low beams. On approaching another vehicle, sound the horn rhythmically.

Driving on mountain roads

Below is some advice for driving on steep mountain roads:

- To prevent the brakes from overheating when driving downhill, use the engine to brake by engaging a lower gear.
- Never coast downhill or drive downhill with the engine off or in neutral.
- Drive at a moderate speeds and do not “cut” corners.
- Remember that overtaking uphill is slower and requires a longer free stretch of road. If you are overtaken when driving uphill, ensure that the other vehicle can pass easily.

3



Driving on snowy or icy roads

Below is some advice for driving in these conditions:

- Keep a very moderate speed.
- Keep a safe distance from the vehicles in front of you.
- Fit snow tyres approved for the vehicle.
- Given the poor grip, use the engine brake as much as possible and avoid sudden braking.
- Avoid sudden acceleration and sharp changes in direction.
- During the winter season, even apparently dry roads can have icy sections.

Therefore, be careful when driving along stretches of road in the shade as there may be icy patches.

Driving with the "ABS" braking system

The ABS system assists the driver as follows:

- It prevents the wheels from locking and skidding during emergency braking, particularly in low-grip conditions.
- It allows braking and changing direction at the same time. This feature is affected by the physical limits and lateral grip of the tyres.
- When the ABS is activated, you will feel a slight pulsing of the brake pedal during emergency braking or in low-grip conditions. DO NOT release the pedal but continue to push it to give continuity to the braking action.
- The ABS prevents the wheels from locking, but it does not increase the physical limits of grip between the tyres and the road: keep a safe distance from the vehicles ahead and reduce speed before curves.

Power steering system

The power steering system uses the power produced by the engine to help the driver steer more precisely while exerting less force on the steering wheel.

Important note



Remember that power steering does not work when the engine is switched off and more force is therefore needed when steering.

Warning



Do not keep the steering wheel fully turned (locked position) to the right or the left for more than 15 seconds when the engine is running. This may damage the power steering system.

Important note



If the power steering system is not working properly, as indicated by a symbol which appears on the left TFT display (see page 106), contact the FERRARI SERVICE NETWORK.



Suspension damping control

This vehicle uses latest generation MagneRide™ magnetorheological suspension, a system developed by Delphi and perfected by FERRARI for continuous automatic damping control.

By processing data received from the vehicle dynamics sensors and sensors that detect bodyshell movements, the ECU interprets the driving conditions and the road surface and immediately adjusts suspension response by varying the control current of each shock absorber.

These sensors allow the ECU to calculate the vehicle speed, vertical and lateral acceleration, steering angle and instantaneous pressure in the braking system, and hence to control suspension damping.

This system not only ensures an optimal compromise between racing-style performance (handling) and comfort, but is capable of emphasising either aspect by using the different adjustments available controlled by the “Manettino” driving mode control switch. Three different setting levels are available on this vehicle.

Level 1 (COMFORT)

Slightly more flexible setting, optimised to better absorb road unevenness and provide a better grip on wet road surfaces (Manettino set to WET).

Level 2 (SPORT)

Slightly more rigid adjustment optimised for sports-style driving and for high speed (with medium-high grip), without significantly affecting comfort (Manettino set to SPORT).

Level 3 (RACE)

Even stiffer setting optimised for occasional use on the race track (RACE, CT OFF and ESC OFF Manettino settings).

3



Driving using the driving mode control switch (“Manettino”)

The driving mode control switch on the steering wheel allows the driver to use the vehicle potential in a fast and intuitive way.

There are five modes available, which correspond to the grip level (from low to high) and consequently to the level of driving assistance required (from high to none).

WET mode

“WET” mode ensures stability on dry as well as on wet roads. It is therefore recommended for low grip conditions (e.g. rain) and on slippery or extremely uneven roads, but also to enhance comfort during city driving. Suspension damping is optimised to provide the best possible absorption (Level 1) and the ESC system is at its maximum level; the standard Bosch ASR system is activated instead of the F1-Trac function.

If “WET” mode is selected, it is indicated on the left TFT display as shown below:

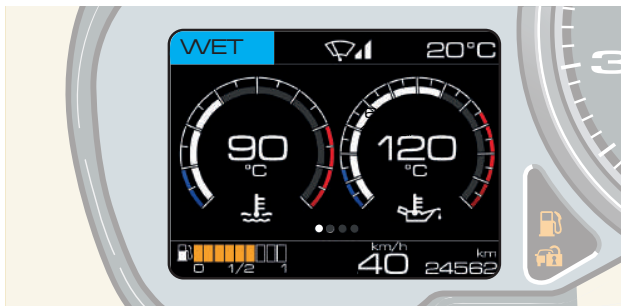

SPORT mode

The “SPORT” mode is the best setting for daily road use. This mode is designed to ensure stability only in medium-high grip conditions. Suspension damping shifts to Level 2 and gearshifting is more racy. The ESC system also switches to a different level offering you greater driving freedom.

If “SPORT” mode is selected, it is indicated on the left TFT display as shown below:

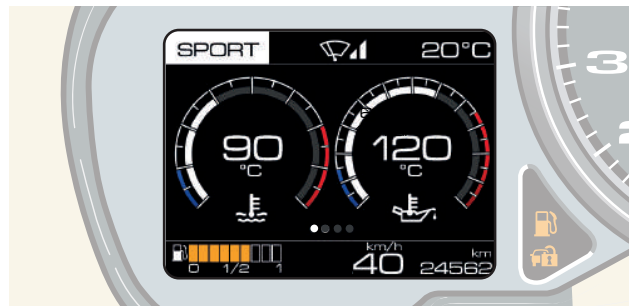



RACE mode

“RACE” mode is preferably for use on the race track, for the purpose of occasional testing. Gearshifting favours the racing style of the vehicle whereas the ESC system shifts to Level 3 (engine power reductions are minimal) and the suspension becomes even stiffer (Level 3). The performance ABS shifts to “Sport” level. This mode is designed to ensure stability on the race track in high grip conditions.

If “RACE” mode is selected, this is indicated on the left TFT display as shown below:

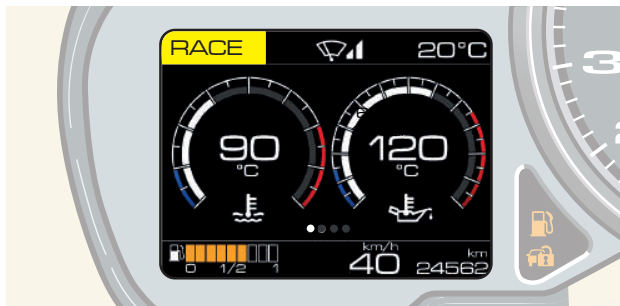

Warning



Test-driving the vehicle occasionally on the race track: after each start, cover the first straight stretch of the track (at least 500 meters) at a constant speed so that the traction control system and the ABS may calculate exactly the grip available and the diameter of the tyres (the calculation is reset every time the engine stops).

If this rule is not followed, system performance may be reduced.

3



CT OFF mode

In “CT OFF” mode the F1-Trac traction control is disabled. This mode further enhances the already racing -style behaviour of the vehicle: traction control is disabled while stability control remains active when a certain level of sideslip is exceeded. The gearshift mode, suspension damping and the performance ABS setting are the same as the previous position. The electronic differential has a specific setting developed to emphasise the dynamic qualities of the vehicle. Stability is not ensured.

If “CT OFF” mode is selected, this is indicated on the left TFT display as shown below:

ESC OFF mode

In “ESC OFF” mode the ESC system is disabled. No electronic systems other than the E-Diff control vehicle stability and the driver is allowed complete freedom and control of the vehicle for track use. The gearshift mode, suspension damping and the performance ABS setting are the same as the “RACE” and “CT OFF” modes.

Warning



In low- to medium-grip conditions (e.g. wet, icy, sandy roads), do not deactivate the **ESC** system.

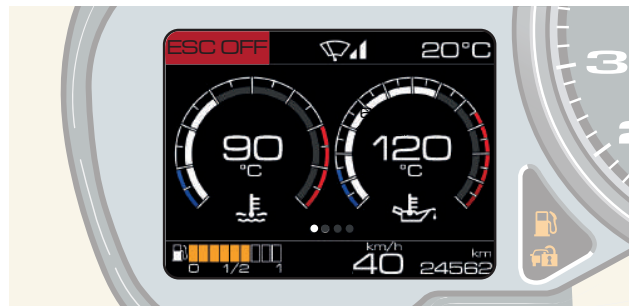
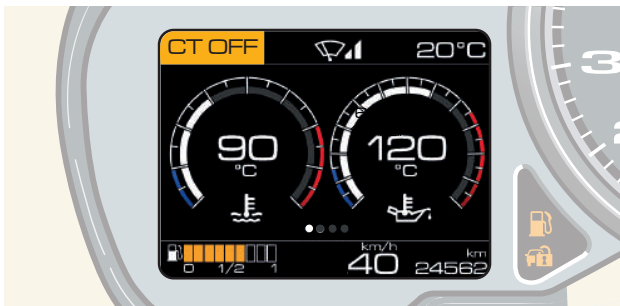



Important note



Every time the engine is started, the **ESC** system will reactivate.

Important note



When the brake pedal is pressed, traction control is activated via the **VDC** system (vehicle dynamics control via the braking system).

If **ESC OFF** mode is selected, this is indicated on the left TFT display as shown below:

3



Suspension damping delink button

The driver may decide to separate the suspension setting from the logic of the “Manettino” driving mode control switch using the special button **A** on the steering wheel.

By pressing button **A**, irrespective of the position of the Manettino, the suspension setting shifts to Level 1 (COMFORT).

Position of Manettino	Suspension setting	Button A pressed
WET	COMFORT	remains COMFORT
SPORT	SPORT	shifts to COMFORT
RACE	RACE	shifts to COMFORT
CT OFF	RACE	shifts to COMFORT
ESC OFF	RACE	shifts to COMFORT

If button **A** has been pressed and subsequently the position of the Manettino is changed, the suspension setting follows the operating logic dictated by the Manettino.

Important note



Upon turning off and restarting the vehicle, the suspension setting depends on the position of the Manettino.

When the Manettino is set to SPORT, RACE, CT OFF or ESC OFF, shifting to the COMFORT suspension setting by pressing button **A** is indicated by displaying the special symbol and “Bumpy road” message on the left TFT display for 5 seconds.





After 5 seconds, next to the Manettino status in the top of the display, the suspension symbol continues to be displayed as shown in the photo below (example shows Manettino in “SPORT” mode).

3

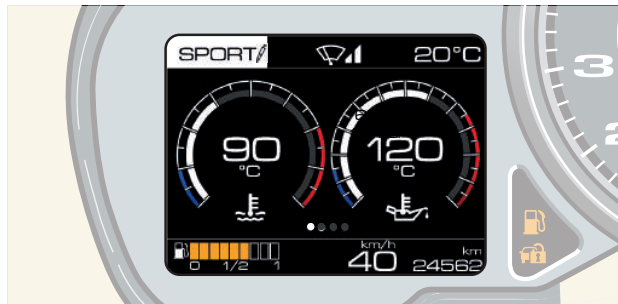



EPB - Electric parking brake

On this vehicle the parking brake is actuated by an electric motor. The parking brake can be applied and released by pulling a special lever **B** on the dashboard to the left of the steering wheel. When the instrument panel is activated, a special warning light comes on on the panel to indicate that the parking brake has been applied (see page 108).

Pull the lever **B** while holding the brake pedal depressed to release the parking brake. The warning light will turn off when the parking brake is fully released.

The electric parking brake may be used as an emergency brake when the vehicle is in motion. If this is the case, the system acts on all four wheels until button **B** is released by communicating with the ESP system which prevents locking.

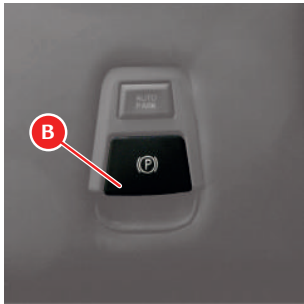

Warning



Always apply the parking brake when the vehicle is parked. The vehicle should be blocked. If this is not the case, please contact the FERRARI SERVICE NETWORK.

Drive Away function

The electric parking brake (EPB) has a “Drive Away” function: when a gear is engaged and the driver presses the accelerator pedal with the engine running and seat belt fastened, the system recognises the driver's intention to drive off and automatically deactivates the parking brake.

EPB deactivation warning

If you try to deactivate the electric parking brake by moving lever **B** without depressing the brake pedal, the message “Depress brake pedal and deactivate EPB”, is immediately displayed on the left TFT display (even during system diagnosis, see page 135) accompanied by an acoustic signal.



Autopark Function

The EPB Autopark function automatically activates the electric parking brake when the engine is switched off. The Autopark function is activated every time the key is turned to on: this means that the driver does not need to apply the parking brake when the engine is switched off.

However, the function can be temporarily deactivated before switching off the engine by pressing the **AUTO PARK C** button: the message “PARK OFF” is displayed on the left TFT display for 5 seconds. In this case, after the engine is switched off, the parking brake must be engaged manually by pulling the lever **B**. To re-enable automatic EPB engagement at the next key-off, press the button **C** again; the message “PARK ON” is displayed on the left TFT display for 5 seconds.

“Automatic Vehicle Holding” AVH function

The electric parking brake provides optimised release when the vehicle starts up due to its Automatic Vehicle Holding function: once the engine has started, the system keeps the vehicle braked through intervention of the braking system rather than through the parking brake shoes.

3

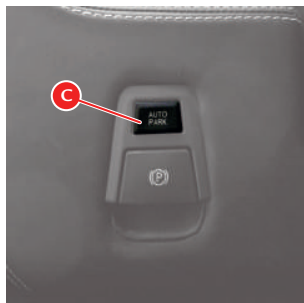



Park Lock

The Park Lock is a locking device built into the gearbox.

This device is used to prevent the vehicle from moving when the multi-disc clutches are open, i.e., with the engine off and/or without the hydraulic pressure required for gearbox operating.

The device operates automatically every time the key is turned to off: if a gear is engaged when the instrument panel is switched off (KEY-OFF), the Park Lock is immediately activated. If the gearbox is in "N" (neutral), the Park Lock starts operating after a minimum preset time (needed for the Carwash procedure, see next paragraph). To inform the driver that the Park Lock has been engaged, the letter "P" is displayed on the gearbox display.

The Park Lock is deactivated when the engine is running, the first gear or "R" is requested (with the brake pedal pressed) and the luggage compartment lid has been closed correctly.

Carwash procedure

The Park lock device can be electrically disabled on a temporary basis when the engine is switched off by performing the Carwash procedure.

This procedure is necessary when the vehicle has to be moved with the engine off and when washing the vehicle.

Warning



When the Park Lock device is electronically deactivated (Carwash procedure), the vehicle may move. The vehicle is only kept stationary by the parking brake which must be applied.

To perform the Carwash procedure, do the following:

- with the engine running, select the first gear;
- select neutral "N";
- switch off the engine;
- activate the instrument panel (KEY-ON) within 3 seconds of switching off the engine.

The message "Carwash mode activation" will appear on the left TFT display.



Launch Control

The “Launch Control” mode is a performance start function. Activating this function optimises vehicle acceleration from a standing start.

The device, which is not available when the Manettino is set to the “WET” driving mode, transfers the necessary torque to the ground and avoids skidding of the wheels during acceleration.

To start the vehicle in “Launch Control” mode, do the following:

- the vehicle must be stationary;
- the gearbox must be in “Manual” mode;
- hold the brake pedal down and select first gear;
- press the **LAUNCH L** button on the left of the centre console: an acoustic signal informs the driver that the device has been switched on and the word “launch” appears on the gearbox display;
- press the accelerator pedal and release the brake pedal.



Important note



The “Launch Control” function is not available in presence of:

- a sloping road surface, even slight;
- high clutch temperatures.

Warning



Only use the “Launch Control” function in appropriate traffic conditions and in optimum safety and road surface conditions.

3



Stop&Start system (optional)

Vehicles with optional HELE (High Emotion Low Emissions) technology are equipped with a Stop&Start system which automatically stops the engine when the vehicle is stationary and restarts it automatically when the driver wants to set off again.

The aim of the Stop&Start function is to increase vehicle efficiency by reducing CO₂ emissions especially when driving around town.

Automatic stopping and restarting of the engine is controlled by sensors and control strategies which, while reducing the impact on vehicle flexibility and comfort to a minimum, guarantee full operating of the safety systems and all the on-board systems even when the engine is switched off, without affecting climate comfort.

Warning



Never abandon the vehicle without switching off the instrument panel (KEY-OFF see page 135).

Never leave children unattended in the vehicle.

Warning



Make sure that the engine is switched off with the instrument panel deactivated before refuelling.

Warning



Always make sure that the Stop&Start system has been deactivated before carrying out any repair and/or maintenance work as indicated on the special labels in the engine compartment and underneath the vehicle.

Failure to comply with the above may pose a risk of serious injury to people working on the vehicle.

Warning



Drivers are responsible for leaving a vehicle with the key inside: drivers must always switch off the engine and instrument panel and take the key with them before getting out of the vehicle.

Warning



Leaving the vehicle with the instrument panel activated puts those who are in the vicinity of the vehicle at serious risk if the engine starts unexpectedly.

Warning



Always switch off the instrument panel and remove the key from the vehicle before changing the tyres.



How the system works

If activated, the Stop&Start system decides when to switch off the engine and when to restart it according to the driving conditions, the climate comfort on board and the operating status of the vehicle. The system logic does not require drivers to make any change in the way they drive the vehicle.

Manual activation and deactivation button

The driver can activate/deactivate the Stop&Start system at any time by pressing button **A** on the roof panel. If the system is activated, pressing button **A** will deactivate it: the message “Stop&Start OFF” appears for 5 seconds on the left TFT display accompanied by a special symbol.

Once the system has been deactivated, pressing button **A** again reactivates the system: the message “Stop&Start ON” appears for 5 seconds on the left TFT display accompanied by a special symbol.

If the Stop&Start system is activated, the LED on button **A** comes on whereas if the system is deactivated, the LED goes off.

Deactivation of the system by pressing button **A** while in a stopped vehicle condition (when the engine has been automatically switched off by the Stop&Start function) automatically restarts the engine.

3





Important note



Each time the instrument panel is switched on (KEY-ON), the Stop&Start system remains in the same state it was in when the vehicle was switched off (KEY-OFF). If the function was activated at KEY-OFF, it remains activated at the next KEY-ON and the LED on button A will flash for a few seconds.

Automatic engine stop mode

The engine stops automatically when the vehicle is stationary and the brake pedal is pressed, and restarts when the brake pedal is released.

The left TFT display informs the driver that the Stop&Start system has been activated by displaying the message “Stop&Start active” accompanied by a special symbol. The message is displayed as long as the vehicle remains in a stop state. To interrupt the display cycle and reduce the message to an icon, press the **MODE** button with “ESCAPE” function.



Stop&Start
ON



Stop&Start
active





Conditions required to activate automatic engine stop

To activate the automatic engine stop while driving:

- **the Stop&Start system must be activated by pressing the button on the roof panel (LED on);**
- **the driver's seat belt must be fastened.**

For safety reasons and to guarantee driving comfort and correct operating of the entire vehicle, automatic engine switching-off is deactivated when:

- the accelerator pedal is depressed;
- a potentially dangerous situation is identified (steep road, vehicle stationary with wheels turned, i.e. when turning at a crossroads or on a roundabout);
- the system recognises vehicle motion in slow traffic or a parking manoeuvre (checking reverse gear engagement, time elapsed since last stop, driving speed);
- maximum air conditioning and heating system performance is requested ("low", "max defrost" or "rear screen demisting");
- external temperatures are very low or very high;
- the gearbox is in the "N" position;
- the Front Lift system has been activated;
- the DCT gearbox Park Lock has been manually released;
- a failure interferes with proper system operating.

The system also constantly monitors some of the vehicle operating parameters (battery charge level, engine coolant temperature, catalytic converter temperature, clutch oil temperature, vacuum level in brake servo, climate comfort in passenger compartment) so that engine switching off can be deactivated in certain conditions to guarantee safety and vehicle operating and minimise the impact on on-board climate comfort.

Important note



After the first cold start, the Stop&Start system may take a few minutes before it is ready. This time period allows some of the engine parameters (catalytic converter temperature, for example) to reach the values required to reduce emissions.

Important note



If the engine continues to run when the vehicle is stationary and the brake pedal is pressed, even if the Stop&Start system appears to be activated, it means that the system has disabled automatic switching off of the engine. When this happens, no specific signal is displayed on the instrument panel: this is to be considered normal.

3



Information on automatic restarting of engine

With the Stop&Start system activated in a stopped vehicle condition, the driver can restart the engine by:

- releasing the brake pedal;
- **UP**-shifting;
- engaging reverse gear;
- pressing the accelerator pedal.

Warning



If the engine is switched off accidentally and not by the Stop&Start system, it must be restarted manually by the driver by pressing the **ENGINE START** button and reengaging the gear using the shift paddles located behind the steering wheel. This condition is indicated on the left TFT display by the message “Press ENGINE START button to restart”, accompanied by an acoustic signal.

For safety reasons and to guarantee comfort when the vehicle is stationary and correct operating of the entire vehicle, the Stop&Start system also automatically restarts the engine when:

- the **ENGINE START** button on the steering wheel has been pressed;
- the function has been deactivated by pressing the button located on the roof panel;
- the driver’s seat belt has been unfastened;
- the driver-side door has been opened;
- the Front Lift system has been activated;
- rear screen demisting has been requested or the air conditioning and heating system set to “low” or “max defrost”.

The system also constantly monitors some of the vehicle operating parameters (battery charge level, engine coolant temperature, catalytic converter temperature, clutch oil temperature, vacuum level in brake servo, climate comfort in passenger compartment, vehicle speed) so that the engine can be automatically started in certain conditions to guarantee safety and vehicle operating and minimise the impact on on-board climate comfort.



Permanent deactivation of automatic restarting and manual start procedures

After automatically switching off the engine using the Stop&Start system, automatic restarting requested by the driver may not always be possible: this means that the vehicle systems have permanently deactivated automatic restarting.

If this occurs, the vehicle must be restarted manually: this condition is indicated on the TFT display by the message “Press ENGINE START button to restart”, accompanied by an acoustic signal.

Warning



If automatic restarting is permanently disabled, the vehicle behaves in the same way as a vehicle with no Stop&Start system: to restart, the driver must perform a manual start by pressing the **ENGINE START** button and using the shift paddles located behind the steering wheel.

Permanent deactivation of automatic restarting occurs when:

- the luggage compartment lid or engine compartment lid are open;
- automatic engine restarting has not been successful;
- a failure has been detected that may interfere with operating of the Stop&Start system.

At times, depending on the seriousness of the failure, the **ENGINE START/STOP** button may have to be held down for a few seconds to restart the engine: this condition is indicated on the left TFT display by the message “Press and hold ENGINE START/STOP button to start”.

3





System failure

If malfunctioning, the Stop&Start system is disabled. The driver is informed of the failure by a special symbol that appears on the left TFT display for 20 seconds accompanied by an acoustic signal and the following message which corresponds to two different alarm levels:

- "Stop&Start failure" (orange symbol).
- "Stop&Start failure. Go to dealer" (red symbol).

Important note



Contact the **FERRARI SERVICE NETWORK** immediately.

When the display cycle ends (20 seconds), or the **MODE** button with "ESCAPE" function is pressed, the message disappears and the symbol is reduced to an icon.

Precautions to be taken during maintenance work

Switch off the instrument panel before carrying out any repair and/or maintenance work on the vehicle. If work has to be carried out on the vehicle with the instrument panel activated, check that the Stop&Start has been deactivated by performing the following procedure before doing any repair and/or maintenance work: if the instrument panel is switched on, switch it off, then switch it on again and then press the Stop&Start system activation/deactivation button on the roof panel (see page 157). If the message "Stop&Start ON" appears on the left TFT display when the button is pressed, press the button again. Check that the message "Stop&Start OFF" appears on the left TFT display for 5 seconds. The button LED must be off.

Warning



NEVER work on the vehicle if the message "Stop&Start active" appears on the left TFT display.



Dome light controls (HELE system only)

On vehicles with the optional HELE system, the central dome light **B** can be switched on or off by holding button **C** or **D** down (for more than 0.8 seconds).

The driver-side spotlight and the passenger-side spotlight can be switched on and off by pressing and quickly releasing buttons **C** and **D** respectively.



Disconnecting the battery (HELE system only)

On vehicles with the optional HELE system, the quick release **E** for disconnecting the battery from the electrical system (see page 224) is located on a dummy negative terminal in the bottom left of the battery compartment.

Warning



After disconnecting the battery from the electrical system, place clamp **E** between bracket **F** and the battery as shown so that it does not come into contact with the dummy negative battery terminal.

3

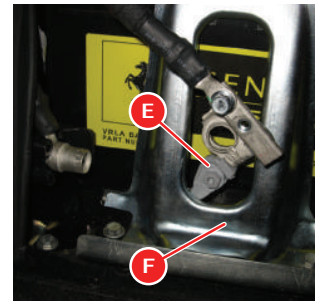
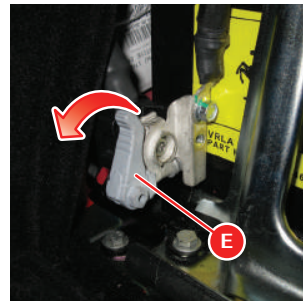



“Front Lift” system (optional)

On request, the vehicle can be fitted with a front suspension lift system: this device acts on the front suspension and raises the front of the car by approximately 40 mm to make access to garages or steep ramps easier and avoid damaging the car.

The system can be activated when the engine is running at a speed of below 40 km/h (25 mph) by pressing button **A** on the dashboard. At speeds of over 40 km/h (25 mph), the system is deactivated whereas if it is already activated, it is automatically deactivated when exceeding 40 km/h.

Throughout the entire Front Lift system activation cycle, the special warning light (see page 108) remains on in flashing mode whereas the vehicle symbol with an arrow pointing upwards and a message “Front Lift moving” appears on the left TFT display. When the system has been activated (front of the vehicle raised), an acoustic signal is emitted and the message “Front Lift ON” appears for 5 seconds whereas the warning light on the panel stays on in fixed mode until the system is deactivated.

To deactivate the system, press button **A** again: at the start of the deactivation cycle, the warning light on the panel starts to flash again whereas the vehicle symbol with an arrow pointing downwards and the message “Front Lift moving” appears on the left TFT display. The message remains until the system has been completely deactivated.

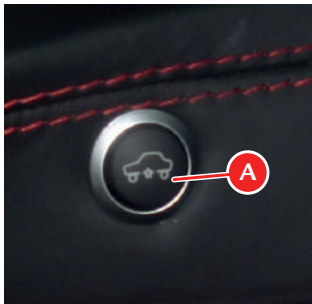



If the engine is turned off with the front suspension lift activated, the following message appears on the left TFT display at key-off: “LIFT ON. Set LIFT to OFF”. Switch on the instrument panel (KEY-ON) and press button **A** to lower the vehicle. If it is not manually deactivated by pressing the button, within 15 seconds of turning off the engine, the system is automatically deactivated.

Warning



The system has not been designed to remain activated when the engine is turned off and the vehicle is stationary. If the engine is turned off with the front lift activated, the vehicle is automatically lowered after 15 seconds.

Do not use the front suspension lift to park the vehicle on obstacles (e.g. pavements); these obstacles may come into contact with the front of the vehicle and damage it once the system has been deactivated.

In the event of engine failure, the “Front Lift” system can however be activated by pressing button **A** for 10 seconds. In this way, the vehicle front can be lifted even in emergencies when the engine is turned off (for example, to load it onto the ramp of a breakdown vehicle).

Important note



The front suspension lift should only be used for the purposes described above and not to drive over speed control systems (e.g. traffic calmers) more quickly.

3

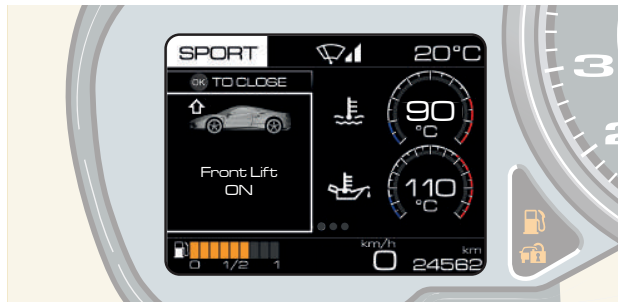



Seat adjustment

Warning



As with all adjustment, seat adjustment must be performed when the vehicle is stationary.

Correct adjustment is very important for enhanced driving comfort and maximum efficiency of the passive safety systems.

Basic seat

The seat position can be adjusted using the special controls.

Backward/forward adjustment

Pull lever **B** up and slide the seat forward or backward to the desired position. Release the lever and “wiggle” in the seat to check that it is locked in place.



Warning



The backward/forward adjustment must consider the fact that airbag devices are placed in front of the driver and the passenger (see page 53).

Correct adjustment must ensure there is adequate space between the airbag and the driver/passenger (see page 53).

Seat back rake adjustment

Turn knob **C** clockwise or counterclockwise until it reaches the required position.





Tilting the backrest

To tilt the seat, pull lever **L** up and push the backrest towards the front of the vehicle.

When the backrest goes back into position, it will automatically block once it has reached the correct position.

3

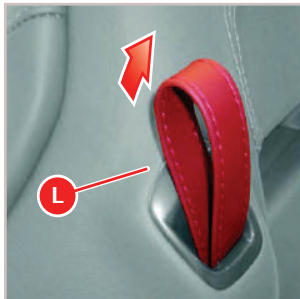



Electrically-adjustable seat (optional)

The seat position can be electrically adjusted using the special controls.

Three adjustments are possible using control **D**:

- backward/forward adjustment: push the control forwards or backwards;
- height adjustment: push the control up or down;
- seat inclination (tilting): push the front or rear end of the control up or down to adjust seat inclination.

Warning



The backward/forward adjustment must consider the fact that airbag devices are placed in front of the driver and the passenger (see page 53).

Correct adjustment must ensure there is adequate space between the airbag and the driver/passenger (see page 53).

Seat back rake adjustment

Use control **E** to adjust the seat back rake. Push the control forward or backward to adjust the seat back rake.

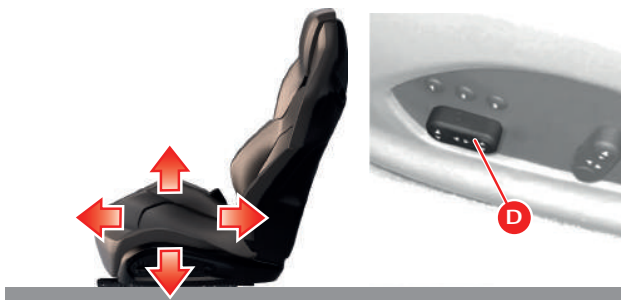



Lumbar support adjustment (Full Electric option)

Use control **F** to adjust the lumbar support. Push the control on the seat symbols to increase or decrease the lumbar support.

Backrest and cushion side width adjustment (Full Electric option)

Use control **G** to pneumatically adjust the width of the backrest sides and the seat cushion. Push the control on the seat symbols to increase or decrease the side width.

Driver's seat position memory (Full Electric option)

When a door is open and the instrument panel is switched off, the seat can be moved for a limited period (approx. 15 sec.). Each time a door is opened or both doors are closed and the key is set to OFF, the seat can be moved again for a limited period.

The seat position can only be memorised when the instrument panel is activated, by pressing one of the three buttons 1, 2 or 3 (**H**) each one corresponding to a memorisable position.

Pressing one of these buttons for longer than 3 seconds memorises the position of the driver seat, rear-view mirrors and steering wheel (confirmed by emission of a double tone).

To recall the memorised position, press one of the buttons **H** and release it within 3 seconds. Operation begins as soon as the button is released.

Recalling the memorised position is not allowed when the vehicle is in motion. If the vehicle starts to move while the memory recall is being operated, the seat and column do not stop moving and reach the memorised position.

With reverse gear engaged, the position of the passenger external rear-view mirror can be adjusted to a position other than the driving position, to help parking manoeuvres. This position can be memorised along with all the other memorisable positions.

If the personalised reverse gear position is never set, when the reverse gear is engaged, the passenger external rear-view mirror will in any case move slightly downwards and inwards (compared with the driving position).

3

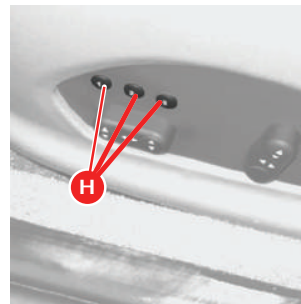



Seat heating system (Full Electric option)

Turn control **N** to activate the seat heating function.

When this function is active on one or both seats, the relative warning light on the panel comes on. Using control **N**, the driver can adjust the heating, choosing from 3 levels identified on the control with the numbers 1, 2 and 3. When the instrument panel is switched off, seat heating is not activated.

Tilting the backrest

To tilt the seat, pull lever **L** up and push the backrest towards the front of the vehicle.

When the backrest goes back into position, it will automatically block once it has reached the correct position.

Warning



Do not use the electric seat adjustment controls when the backrest is tilted.

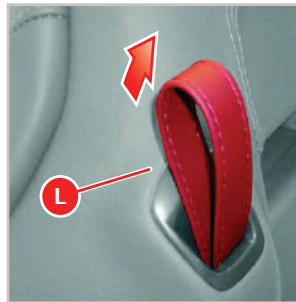
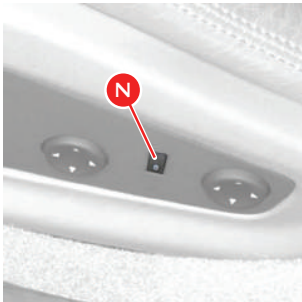



Racing seat (optional)

The seat position can be adjusted using the special controls.

Backward/forward adjustment

Pull lever **P** up and slide the seat forward or backward to the desired position. Release the lever and “wiggle” in the seat to check that it is locked in place.

Warning



The backward/forward adjustment must consider the fact that airbag devices are placed in front of the driver and the passenger (see page 49).

Correct adjustment must ensure there is adequate space between the airbag and the driver/passenger (see page 49).

3

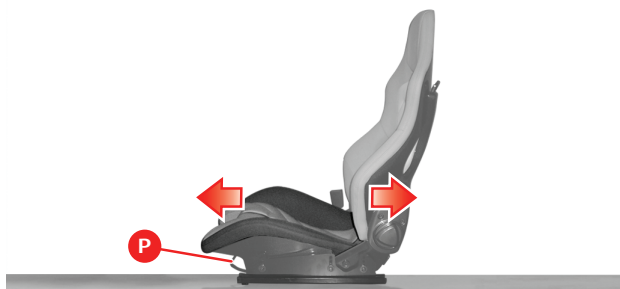



Seat back rake adjustment

Turn knob **Q** clockwise or counterclockwise until the desired back rake has been reached.

Tilting the backrest

Pull lever **R** up to tilt the backrest forward.

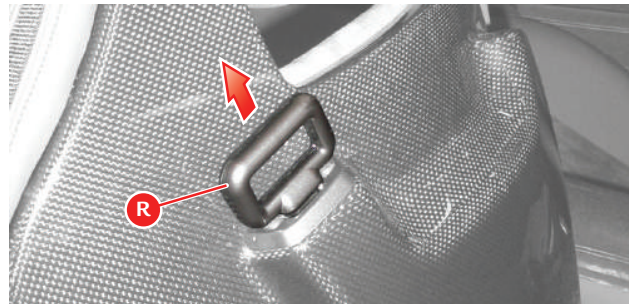
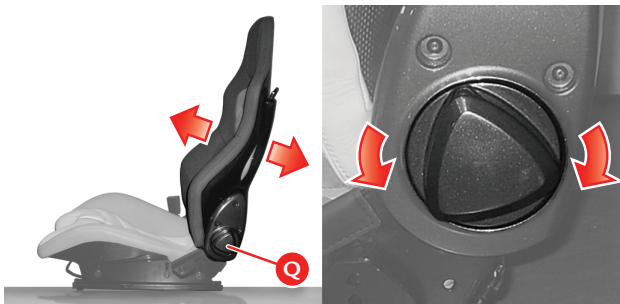



Adjusting the steering wheel

The steering wheel can be adjusted for rake and reach.

Warning



Do not adjust the steering wheel when the vehicle is moving.

Mechanical adjustment

- 1) Release lever **X** by pushing it forwards.
- 2) Adjust the position of the steering wheel.
- 3) Block the steering wheel by pulling lever **X** until it locks into position.



Electric adjustment (optional)

It can only be adjusted if the instrument panel is activated. Move control **A** to the left of the steering column. On versions with a driver's seat with memory, the position of the steering wheel is memorised together with the position of the external rear-view mirrors when the seat position is memorised.

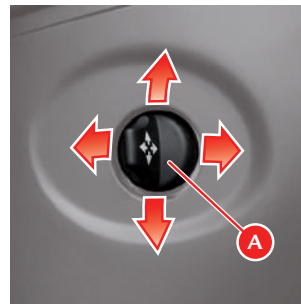

3



Rear-view mirrors

Internal rear-view mirror

Hold the internal rear-view mirror and move it to the required position.

On request, the internal rear-view mirror can be fitted with an electrochromic mirror that automatically darkens to reduce the dazzling effect of the reflected light on the driver. The speed with which the mirror darkens depends on the intensity of the light.

By pressing button **B** you can activate/deactivate the electrochromic mode. When the electrochromic mode is activated, the green LED **D** comes on.



External rear-view mirrors

These mirrors can be electrically adjusted using the control **C** (with the instrument panel activated) and are equipped with defogging elements.

- 1) Mirror selection: turn control **C** to the left or right lock position to select the mirror that requires adjusting.
- 2) Mirror positioning: move control **C** in the four directions (up – down – right – left) to adjust the selected mirror.
- 3) Mirror closure (optional): turn control **C** to the lower central lock position to close the rear-view mirrors.

Once adjusted, move the control **C** into the upper central position where it will be locked in order to avoid changing the external mirror setting inadvertently.

The mirrors will yield in both directions in the event of a collision: if necessary, the mirrors can be pushed both backwards and forwards.

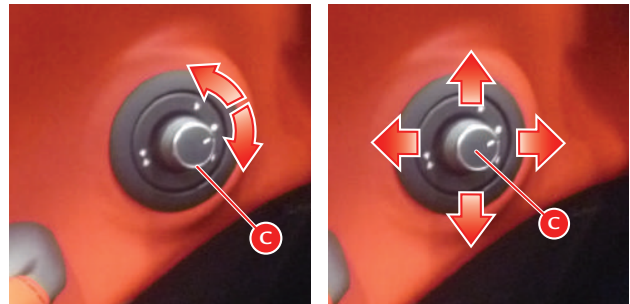



Warning



The rear-view mirrors must always be positioned correctly while driving.

Do not adjust the rear-view mirrors when the vehicle is moving.

On request, the external rear-view mirrors can be fitted with an electrochromic mirror.

3



Air conditioning and heating system

Operating modes

Automatic

This mode automatically adjusts the air distribution, temperature and ventilation levels according to the temperature set by the user.

Partially Automatic

This mode allows the user to adjust certain parameters manually, while others remain automatic.

Manual

This mode allows the user to set the values to suit the passengers' needs.

Controls

- 1 Left-hand temperature setting and **AUTO** button
- 2 A.C. compressor activation/deactivation
- 3 Single-zone mode activation/deactivation
- 4 Air distribution fan speed
- 5 Enable/disable rear screen and rear view mirror demist function
- 6 Windscreen demist activation/deactivation
- 7 Right-hand temperature setting and **AUTO** button
- 8 Right-hand air distribution mode setting
- 9 Air recirculation
- 10 Left-hand air distribution mode setting.

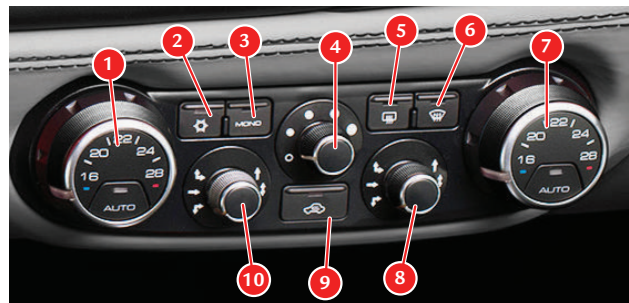



Left-hand temperature setting and AUTO button (1)

This is used to select the required air temperature in the left-hand side of the passenger compartment; the **AUTO** button is used to activate automatic operation (LED on).

A.C. compressor activation/deactivation (2)

This is used to activate (LED on) or deactivate (LED off) the A.C. compressor.

Single-zone mode activation/deactivation (3)

This is used to activate (LED on) or deactivate (LED off) the single-zone operating mode.

Air distribution fan speed (4)

The four setting positions allow the occupants to select the air flow rate.

Enable/disable rear view mirror demist function (5)

Press (LED on) to activate rear view mirror defogging/demisting.

Windscreen demist activation/deactivation (6)

Press this button (LED on) to activate windscreen defogging/demisting.

3

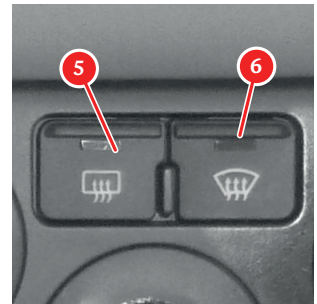
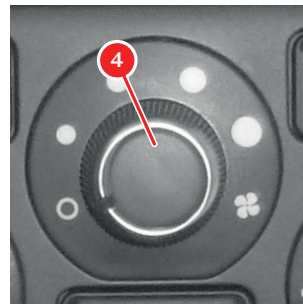
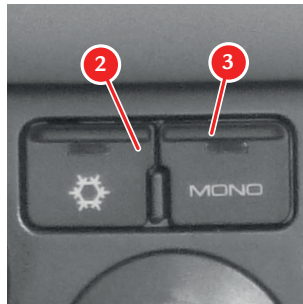



Right-hand temperature setting and AUTO button (7)

This is used to select the required air temperature in the right-hand side of the passenger compartment; the AUTO button is used to activate automatic operation (LED on).

Right-hand air distribution mode setting (8)

This is used to select one of the six air flow distribution modes in the right-hand side of the passenger compartment.

Air recirculation (9)

If released (LED off), the air flow comes from outside the passenger compartment.

When outside temperatures exceed 32 °C (90 °F), the air recirculation feature remains on with a 60-second pause every twenty minutes to refresh the air.

If you activate the windscreen washer function, the air recirculation feature activates for 20 seconds, to prevent any smell of detergent products from entering the passenger compartment.

If pressed (LED on), the air flow comes from inside the passenger compartment.

The recirculation increases air heating or cooling.

Left-hand air distribution mode setting (10)

This is used to select one of the six air flow distribution modes in the left-hand side of the passenger compartment.

Once the internal temperature has stabilised at the desired level, you are advised not to change the position of the temperature selection switch unless the external temperature changes drastically.

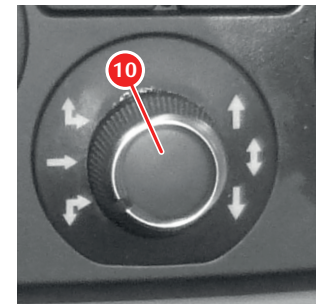
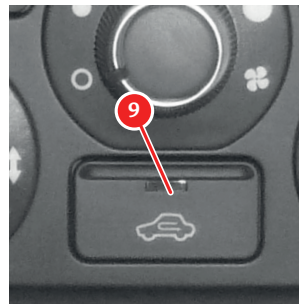
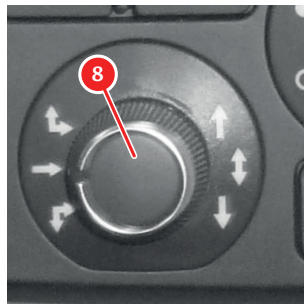



Adjusting the air vents

The adjustable air vents are positioned on the sides and in the central section of the dashboard.

Use control **A** to direct the air flow

Use control **B** to adjust the air flow rate.

Turned to left: closed.

Turned to right: open.

Important note



We recommend keeping the air flow set to open and directing the air flow to a neutral position.

Maintenance

The pollen filter must be replaced every year, as indicated in the “Maintenance Schedule”.

Important note



The air coming out of the vents does not correspond to the temperature requested by the user, but is the temperature required to maintain the desired temperature inside the passenger compartment.

3

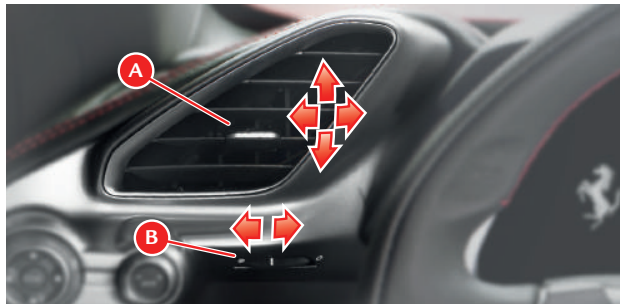



Passenger compartment accessories

Glove compartment

This is located on the passenger side of the dashboard.

Oddment storage compartments

They are located on the lower part of the doors and on the centre console.

There is also a compartment for storing the vehicle key in the front of the centre console.





Sun visors

The sun visors can be moved by pulling them down towards the windscreen and sideways by unhooking them from the fastener and turning them towards the door glass.

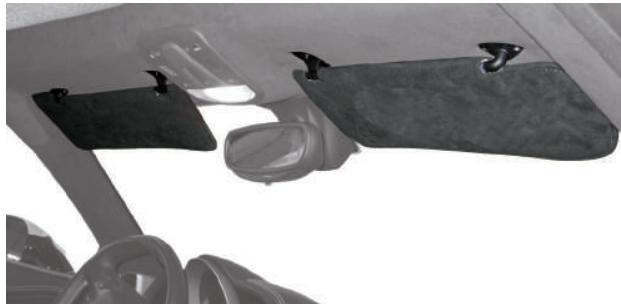

12V power socket

The power socket **D** on the centre console can be used to power small electrical appliances such as mobile phones, lights, vacuum cleaner and any other accessory with absorption not exceeding 140 Watts and a voltage of no more than 12 Volts.

Warning



Prolonged use of this device may discharge the battery.

Do not try to insert plugs into the power socket that are not the right size and shape.

3

Warning



Use the power socket to connect the tyre repair and inflation kit in an emergency **ONLY** for the amount of time strictly necessary.

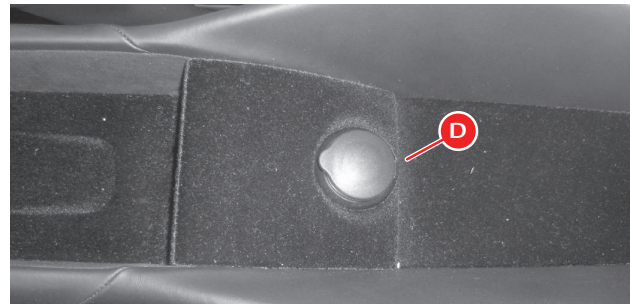



Infotainment system

Characteristics

The built-in infotainment system is displayed on the right TFT display and, when it is switched on, the speedometer is displayed on the left TFT display. The infotainment system includes the following functions:

- FM/MW/DAB radio (in the countries where available).
- CD player (optional).
- USB/iPod®/iPhone® connector.
- Satellite navigator.
- Bluetooth connection.

Recommendations

This manual contains indications (recommendations and information) intended to avoid actions that may cause accident or injury. Please observe all recommendations.

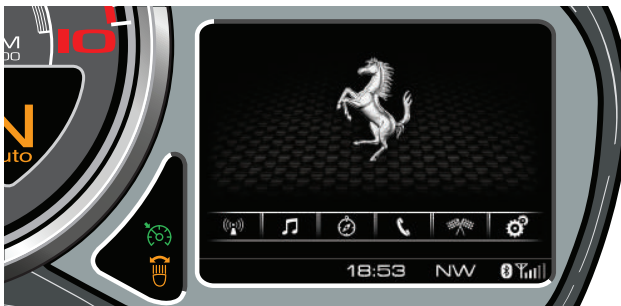

Safety information

Read this manual carefully before using the navigation system for the first time. Observe the safety information described in the manual. Contact the vehicle manufacturer if in any doubt.

Intended use

The navigation system complies with the standards used in navigation technology.

Always be aware of the regulations and guidelines in force in the country where the vehicle will be used.

Software update

The navigation data software can be updated. For the most recent software, contact the FERRARI SERVICE NETWORK.

Using the infotainment system safely

First of all, read the instructions in the manual carefully in order to use the system correctly. We do not recommend that it is used by children without the supervision of an adult.

Playing music at a very high volume can cause permanent damage to hearing and can be distracting for the driver, especially when driving at high speeds. Therefore, carefully adjust the volume.

Driving requires your full attention and care. If you are driving, we do not recommend using the infotainment system.



Important note



Several system functions depend on vehicle speed.

Keep the system away from liquids and others sources of humidity.

Connections

Do not force the connectors. Before connecting them, make sure that the connectors are the correct shape and size.

The connected cables must not exert any pressure on the connection.

CD player (optional)

Do not insert damaged, warped, scratched or dirty CDs into the CD player.

Discs that have been modified with an adhesive label should not be inserted in the CD player.

Do not insert more than 1 (one) CD at a time into the drive slot.

Insert supported CD formats only. See the “Disc Mode” section on page 190 for information on supported CD formats.

Other electronic devices

Other electronic devices (PDA, iPod, computer laptop, etc.), may be used in the vehicle, some of which may cause electromagnetic interference with the GPS antenna. If you notice a reduction in GPS performance, switch off all appliances and move them as far away as possible from the GPS antenna.

Warning



As indicated in the general remarks referred to here, the driver can be distracted by a number of factors including the navigation/infotainment systems. The infotainment system should be used by the passenger where possible and, if used by the driver, should only be used when the vehicle is stationary.

3



User interface

The infotainment system information is displayed on the right TFT display. The user can interact with the system by using the commands on the dashboard to the right of the steering wheel. Commands are also situated on the back of the steering wheel.

Controls on dashboard

Hold down button **G** to switch the infotainment system on and off and press and quickly release button **G** to activate the MUTE mode (no audio).

Press and quickly release button **H** to display the options for the displayed screen and press and hold down button **H** to select whether to display infotainment system information or the speedometer.

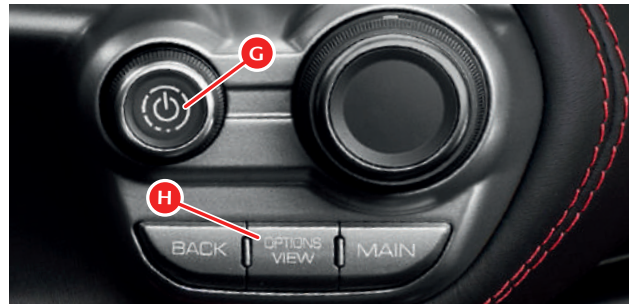
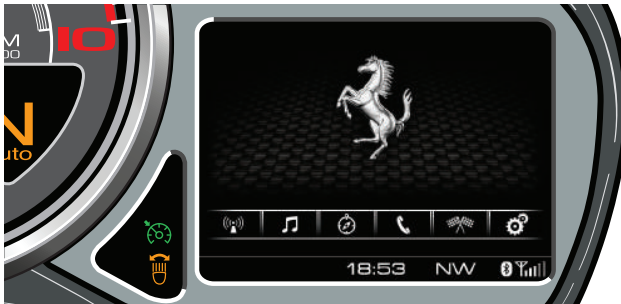



The joystick **I** can be rotated clockwise and anti-clockwise, can be moved in the four directions indicated by the arrows or can be pressed centrally using the Enter function.

If the displayed menu has several pages (e.g. NAV, MAP), moving the joystick **I** up takes you to the menu page selection mode.

Button **L** takes you to the previous screen by moving up the menu levels.

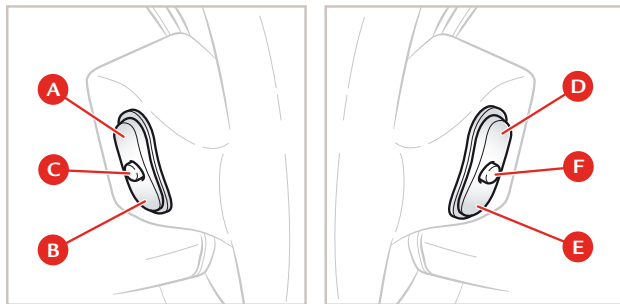
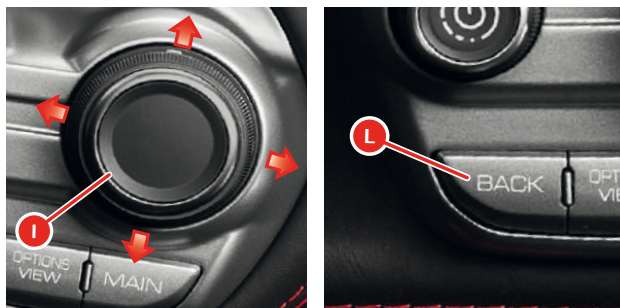

Controls on the steering wheel

Some functions in the infotainment system can be controlled using buttons located on the top and back of the steering wheel as indicated by the arrows in the figure.

Buttons **A** and **B** for volume control and button PTT **C** are on the left-hand steering wheel spoke: press button **A** to increase the volume and press button **B** to decrease it. Hold down button **B** to mute the volume (MUTE function). To deactivate volume muting, press button **A**. Button **C** is used to activate the voice commands; if the voice recognition function is already activated, it can be deactivated by quickly pressing button **C**. If there is an incoming call, quickly press button **C** to accept it or hold it down to refuse it.

The SCAN + **D** and SCAN - **E** buttons are on the right-hand steering wheel spoke. They are used to scan the radio stations (if RADIO mode is activated) or go to the next or previous track (if MEDIA mode is activated). The SOURCE **F** button lets you select the available sources.

3





System settings

To access the system settings from the main screen, select **SETTINGS** or press the **OPTIONS** button on the right satellite.

Audio control

Once you are in the **SETUP** menu, press the “Audio” soft key to access the audio control menu. You can adjust the balance/fading and equalisation of the stereo system, activate/deactivate “Quantum Logic” (if present) and adjust the volume according to the speed on this page.

To adjust the balance and fading, press the arrow soft keys.

The equalizer settings can be used to adjust the bass (**BASS**), mid (**MID**) and treble (**TREB**) levels.

Press the “Quantum Logic” soft key to activate/deactivate the option.

The volume can be adjusted to the speed on 3 levels or deactivated.

Adjusting display brightness

From the main screen, press the **OPTIONS** button on the right satellite or select **SETTINGS** and then “Screen”. To set the display brightness, select **Day**, **Night** or **Auto**.

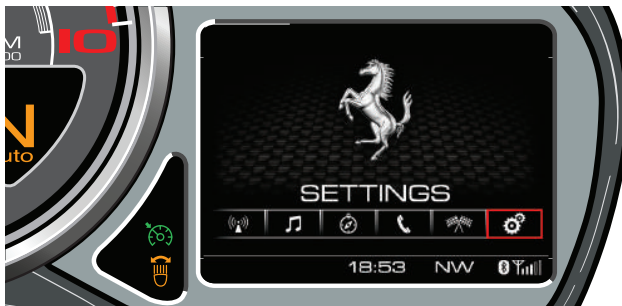



Pairing a Bluetooth Phone/Audio device

From the main screen of the navigator, press the OPTIONS button on the right satellite or select SETTINGS and then “Audio/Tel. Bluetooth”. Press the “+ Add Device” soft key to pair a new Bluetooth device (telephone, tablet, laptop, etc.) and follow the instructions displayed on the screen.

The icons on the right showing a phone and music indicate to the user the type of device connection and whether it is music only, phone only or both.

After pairing and selecting a peripheral, press the OPTIONS button on the right satellite to access the Bluetooth device settings. Here you can tell the system to give priority to the peripheral selected using the “Setting Priority” option.

The system will ask you to pair your mobile phone: search for Bluetooth devices from the phone, select “Ferrari”, then enter the PIN.

A confirmation message is displayed on the screen once pairing is successful.

3





RADIO function

Select RADIO from the main menu to access the desired mode. To navigate between the sections FM, MW (or AM where applicable) and DAB (in the countries where available) use the joystick.

Selecting a radio station

Once you have selected the desired band, you can begin automatic scanning of the radio stations by turning the right button or manually enter the desired frequency by using the numeric keypad which can be accessed from the Radio options menu (see page 189). You can also select the desired radio station from a list by pressing the “List” soft key. The list has two display options - the first shows the radio stations stored as “Favourites” whereas the second shows the radio stations with the strongest signal in the area. To change display mode, press the “Go to favourites/Go to strong stations” soft key at the top of the list.

Storing favourite radio stations

You can store your favourite radio stations for each frequency band. To preset a favourite radio station, press and hold the joystick down on “Hold down to preset”.

Scanning favourite radio stations

To display the list of stored stations, press the “List” soft key in the bottom part of the display and select the “Go to favourites” display mode.





DAB radio

Digital radio (in the countries where available) has some additional options: artists/musical genres can be indicated as favourites.

Radio settings

When you are in one of the three bands FM, MW or DAB (if available), press the **OPTIONS** button on the right satellite to access the settings menu.

3





MEDIA function

Select MEDIA from the main menu to access the desired mode. To navigate between the sections DISC (if present), BLUETOOTH and USB use the joystick on the right satellite.

Disc mode (DISC)

If the system has a CD player (optional), it is installed in the glove compartment on the passenger side:

Important note



When placing a disc in the player slot, make sure the label is facing upwards.

Insert the disc in the slot: the system pulls it into the player. Once it has recognised the disc, the system selects the appropriate mode and starts to play the first track.

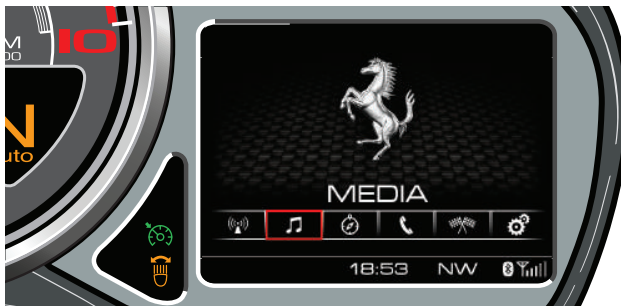

Warning



The player only accepts 12 cm (4 3/4 inch) discs. Using discs of any other format may damage the player mechanism.

The system can play compact discs (CD), recordable compact discs (CD-R) and rewritable compact discs (CD-RW).

The system plays these formats: MP3, WMA, CD Audio.

Insert supported formats only.



Playing a disc

After inserting a disc in the player, the system selects the appropriate mode once it has recognised the disc and starts to play the first track.

To go on to the next or previous track, you can use the joystick **I** on the right satellite or the buttons **D** and **E** behind the right-hand spoke of the steering wheel.

To display and scroll through the list of multimedia content on the CD, press the “List” soft key in the bottom of the display.

If the “Shuffle” play mode is activated, the icon is displayed on the screen .

Disc mode settings

While you are in disc mode with a disc inserted, press the **OPTIONS** button on the right satellite to access the options menu. Here you can activate/deactivate the “Shuffle” mode, activate/deactivate the “Repeat” mode, select the right button operating mode (FF/FRW or go to beginning/go to end) and access the “Audio Settings”.

3





Bluetooth mode

In Bluetooth mode, you can play audio files stored on external devices. These can be connected to the system via the Bluetooth connection once the device has been paired (see page 187).

Important note



The “List” function cannot be used in Bluetooth mode.

Bluetooth mode settings

While you are in Bluetooth mode with a paired peripheral, press the OPTIONS button on the right satellite to access the options menu. Here you can activate/deactivate the “Shuffle” mode, activate the “Repeat” mode, access the Bluetooth device settings and access the “Audio Settings”.



USB mode

The USB mode provides access to the files in the USB peripheral connected to the system via connector **A** in the pocket change compartment on the centre console.

USB connection

Using the USB connector, you can also play audio files from iPod® and iPhone® devices, using the USB cable supplied with the device.

Warning



Do not force connectors into the infotainment system ports. Before connecting, make sure that the connectors are the same shape and size as the port.

Playing multimedia content is the same as the disc mode (see page 190).

USB mode settings

While you are in USB mode with a paired USB peripheral, press the OPTIONS button on the right satellite to access the options menu. Here you can activate/deactivate the “Shuffle” mode, activate/deactivate the “Repeat” mode, select the right button operating mode (FF/FRW or go to previous track/next track) and access the “Audio Settings”.



Satellite navigation system function (NAVIGATION)

Warning



Drive carefully, keep your eyes on the road and comply with road regulations.

Select NAVIGATION from the main menu to access the desired mode.

Main Navi menu

The main NAVI menu has the following menu items:

- **Stop Guidance** (only when the Navigation mode is activated)
- **Show Map**

Select "Show Map" to display a map of your current position. See the "Show Map" section for details.

- **Destination Entry**

Select "Destination Entry" to program a destination.

- **Recent Destinations**

Select "Recent Destinations" to call up a recent destination.

- **Go Home**

Select "Go Home" to follow the route to your preset "Home" position.

3





- Favorites

Select "Favorites" to enter a point of interest from a list of preselected favourite places, also available when the vehicle is moving.

- POI (Point of Interest)

Select "Point of Interest" to select a destination from the list of positions, public places or points of interest. Search by name, telephone number, category or type of place.

- Emergency

Select "Emergency" to follow a route to an emergency facility near to the current location of your vehicle. This includes the fire brigade, police, hospitals.

- Trips

Select "Trips" to enter a point of interest from a list of previously saved routes.

- Where Am I?

Select "Where Am I?" to find your current position.

- On-board computer

Select "On-board computer" to display information on the position and speed detected by the satellite.





Destination entry using an address

Important note



For your own safety and the safety of your passengers, you cannot use the keyboard while the vehicle is in motion.

Select “Enter Destination” and as you enter the name, the number of possible roads is reduced (in the countries where this is available). You can always switch the keypad from “letters” mode to “numbers” mode or “symbols” mode by pressing the soft keys at the bottom of the screen.

If you do not enter the house number, the navigation system will guide you to the closest end location on the entered street.

You can also select the destination from a list of recent/favourite destinations by selecting “List”.

You can always stop navigation by selecting the relevant item on the main navigation system screen.



NAVI settings

To access the navigation system settings, go to the main NAVI screen and press the OPTIONS button on the right satellite.

MAP settings

Once the suggested route has started, you can modify navigation parameters on the MAP screen by pressing the “OPTIONS” button on the right satellite.

3



Telephone function

The telephone function is a hands-free in-vehicle communications system that allows you to dial a phone number with your mobile phone by using simple commands or the soft keyboard that appears on the display.

Your phone's audio is transmitted via the vehicle audio system; when the telephone function is used, the infotainment system automatically mutes the car radio.

To use the telephone function, you must first of all pair a Bluetooth-compatible mobile phone. (see page 187).

Important note



2 phones can be active and connected to the system, one with the "Phone" function and one with the "Audio streaming" function (playing of music). A phone which has been assigned the "Audio streaming" function cannot be used for the "Phone" function and vice versa.

Select PHONE from the main screen to switch to Phone mode. Five icons are displayed in the bottom of the display which can be used to access the functions: Contacts, Favourites and Recents, Messages (if the device is compatible with this function) and numeric keypad.

Making a call

To make a call, you can select a contact from the "Contacts", "Favourites" or "Recents" lists or manually enter the phone number using the soft keyboard that appears on the display; to redial, use the icon  displayed on the main "Phone" screen.





Voice commands and PTT (Push-To-Talk) function

The Push To Talk function is a hands-free in-vehicle communications system that allows you to navigate the system by using voice commands.

To call up this function, press button **C** behind the left-hand spoke of the steering wheel. Button **C** is used to activate the voice commands; if the voice recognition function is already activated, it can be deactivated by quickly pressing button **C**. If there is an incoming call, quickly press button **C** to accept it or hold it down to refuse it.

If you give the voice command “**Guidance**”, the system reads out a list of voice commands for the displayed screen.

The voice recognition system is flexible and identifies a set of words pronounced by the user by extracting the meaning to activate the desired function. For example, different phrases can be used to call up the same function.

For example, in the relevant screen, if you say “Connect telephone” or “Pair telephone” the system activates the same function. You can therefore speak freely because the system is designed to understand commands even if different words are used.

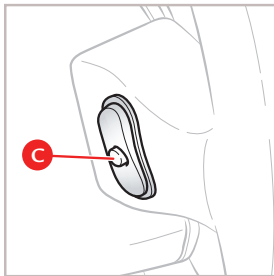

When a phone/device is connected, press and hold down button **C** to activate the voice recognition function which is built into the phone/device (if compatible).

3



Passenger display (optional)

The passenger display **B** (available on request) has been designed to allow the front passenger to participate more in trips and provides access to a number of vehicle parameters which are normally only available to the driver.

The passenger display shows information displayed on the following screens on the instrument panel:

- **Performance:**
engaged gear, RPM, speed.
- **TRIP A:**
distance travelled, travel time, average and maximum speed.
- **TRIP B:**
distance travelled, travel time, average and maximum speed.
- **Manettino status:**
Manettino position and vehicle parameter status.

Hold down the **DISP** button **A** to switch the passenger display on and off. Quickly press button **A** to switch from one screen to another.

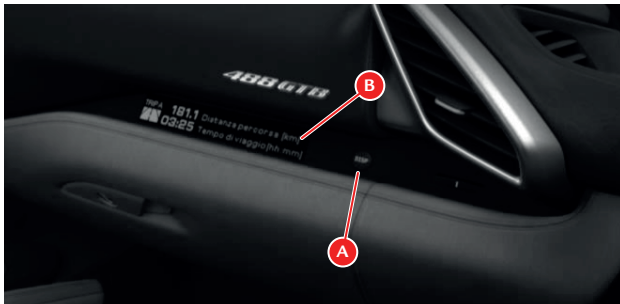



3

Toolkit	202
Emergency start/stop	204
Replacing light bulbs	209
Replacing a fuse	212
List of fuses	214
Replacing a wheel	220
Towing	222
Battery	224
Battery conditioner	228
EPB emergency release	232
Park Lock emergency release	234



ADVICE FOR EMERGENCY SITUATIONS



Warning



Repair work using the toolkit requires:

- suitable protective equipment (e.g. gloves);
- adequate precautions to be taken (e.g. during tyre replacement never lie under a vehicle raised by a jack);
- minimum specific expertise when working in contact with electrical parts/components (e.g. battery).

Toolkit

Tool bag

Stored in the luggage compartment, it contains the necessary tools for emergency repair jobs:

- pair of cotton gloves;
- set of fuses;
- pliers for removing fuses;
- tow hook;
- Allen key;
- funnel for emergency fuelling;
- screwdriver for slotted and crosshead screws;
- EPB emergency release tool;
- Park Lock emergency release tool and extension.





Warning



The Electric Parking Brake (EPB) emergency release tool and the Park Lock emergency release tool may only be used by specialised workshop personnel, as indicated on the label in the tool bag.



Emergency start/stop

The new FERRARI keys use a Key-Less vehicle ignition system which can switch on the instrument panel and then the engine by simply placing the key inside the passenger compartment. The dedicated ECU recognises the vehicle key by the electronic ID code it contains. The ENGINE START/STOP key on the steering wheel controls KEY-ON, KEY-OFF, ENGINE START and ENGINE STOP.

If the key battery is completely flat, there is a button **K** for emergency switching on and off of the engine located under the cosmetic shield in the front of the centre console.

For emergency switching on, put the key next to button **K** making sure that the rear part of the key and the button are in contact. While holding the key in a perfectly vertical position above button **K** with one hand, perform the normal engine ignition procedure.

Warning



The vehicle **CANNOT** be started by pressing the emergency button **K**. During emergency starting, button **K** only checks the key code.

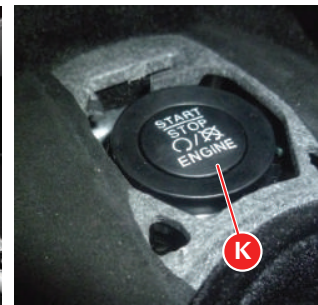



For emergency switching off when the vehicle is stationary, press button **K** once. If the vehicle is in motion, press and hold button **K** down for at least 2 seconds (alternatively, press the button quickly 3 times in succession).

4





Emergency tyre repair and inflation kit

Stored in the luggage compartment, it can be used in the event of a puncture or low tyre pressure to repair and/or inflate a tyre enough to continue the journey safely.

Important note



To use the tyre repair and inflation kit correctly, refer to the instruction booklet provided with the kit.

Warning



Give the instruction manual supplied with the kit to the personnel that will handle the tyre repaired with the tyre repair kit.

Warning



In the event of a puncture caused by foreign objects, tyres can be repaired with cuts of up to **4 mm** in diameter on the tyre tread and shoulder.

Warning



Punctures cannot be repaired on the sides of the tyre. Do not use the tyre repair kit if the tyre has been damaged after driving with a flat tyre.

Warning



Damage to the wheel rim that causes air leaks cannot be repaired. Do not remove foreign objects (screws or nails) that have penetrated the tyre.

Warning



After using the repair kit, the vehicle must be considered in an emergency situation: drive with the greatest care (maximum permissible speed 80 km/h).

Warning



Apply the sticker supplied with the kit where it can easily be seen by the driver to indicate that the tyre has been treated with the tyre repair kit.

Drive carefully especially on bends.
Avoid sudden accelerations or braking.

Warning



The kit is to be used to temporarily repair only one tyre punctured by small objects: the kit may not be useful in the case of large punctures or tearing.



Important note



After driving for approximately 10 minutes, stop and recheck the tyre pressure.
Remember to apply the parking brake.

Warning



If the pressure has decreased below **1.8 bar** (26.11 psi), do not continue driving: the kit cannot guarantee the correct hold because the tyre is too damaged. Contact the FERRARI SERVICE NETWORK.

If the tyre pressure is at least **1.8 bar** (26.11 psi), restore the correct pressure and continue driving.

Drive very carefully to the nearest FERRARI SERVICE NETWORK.

Warning



The repaired tyre must be replaced as soon as possible and the workshop personnel must be informed that the tyre was treated with tyre repair fluid.

Warning



Keep the kit in its box and out of children's reach.
Do not inhale or swallow the fluid contained in the cartridge and avoid contact with the skin and eyes.

Warning



The spray contains ethylene glycol and latex.
The latex may cause an allergic reaction, is harmful if swallowed and is irritating to eyes. May cause sensitisation by inhalation and skin contact. Avoid contact with eyes, skin and clothing.
In case of contact, rinse immediately with plenty of water. If swallowed, do not induce vomiting, rinse mouth, drink plenty of water and seek immediate medical advice. Keep out of reach of children. The product should not be used by asthma sufferers.
Do not inhale vapours during use. In the event of an allergic reaction, seek immediate medical advice. Store the spray can in its special case away from sources of heat.
The liquid sealant has an expiry date: the expiry date is indicated on the kit.

4



Environment



Replace the spray can containing the expired liquid sealant. Do not dispose of the spray can and sealant in normal domestic waste. Dispose of in accordance with national and local regulations or ask the FERRARI SERVICE NETWORK to take care of disposal.

Warning



The sealant in the kit cartridge can damage the sensor inside the wheel rim on vehicles fitted with a tyre temperature and pressure monitoring system (TPMS).

If this occurs, the sensor must be replaced. Contact the FERRARI SERVICE NETWORK.

Warning



Wear the protective gloves supplied with the tyre inflation and repair kit.

Useful accessories

In addition to the tools supplied with the vehicle, the hazard warning triangle and fluorescent safety jacket should always be kept on board in order to signal hazardous situations in compliance with regulations.



Replacing the front and rear light bulbs

Important note



To replace the front and rear light bulbs, contact the **FERRARI SERVICE NETWORK**.

To adjust the headlight beam, please contact the **FERRARI SERVICE NETWORK**.

Replacing number plate light bulbs

To replace a number plate light bulb, proceed as follows:

- remove the light from the right side where there is a spring clip;
- remove the transparent cover **A** from its housing;
- replace the bulb by removing connector **B** from its housing;
- refit the connector and transparent cover by inserting it first from the left side and then pressing on the other side.

4

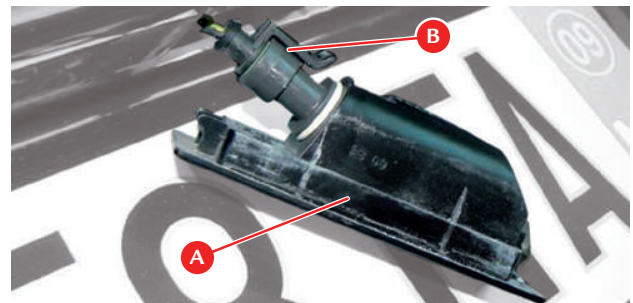



Replacing other light bulbs

Roof dome light

- Use a screwdriver to gently prise under the edge of the transparent cover **C** of the dome light and remove it from the roof panel.
- Replace the bulb **D** or **E** or **F**.
- Refit the dome light and make sure that the wires are not trapped by inserting it first from the connector side and then pressing on the opposite side.

Underdoor light bulbs

- Prise gently under the edge of the transparent cover with a screwdriver and lift the cover.
- Completely remove the transparent cover from its housing.
- Take the bulb out of its clips.
- Replace the bulb.
- Refit the transparent cover and make sure that the wires are not trapped by inserting it first from the connector side and then pressing on the opposite side.

Follow the same procedure for replacing the underdoor light bulbs and the luggage compartment dome light bulb.

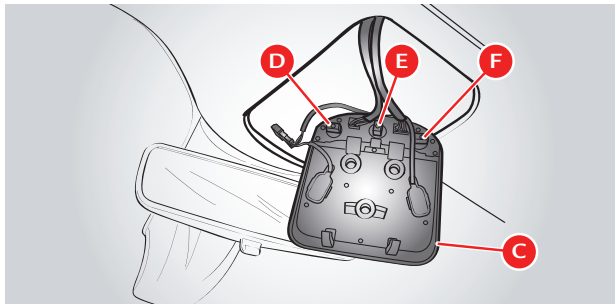



Light bulbs (12 V except for high beam and low beam)

	Type	Power
Low beams and high beams	gas-discharge (XENON)	Das
Front running lights	LED	
Front turn indicator lights	LED	
Side turn indicator lights	incandescent	T4W
Running and stop lights	LED	
Reverse lights	LED	
Supplementary stop lights	LED	
Rear turn indicator lights	LED	
Rear fog lights	LED	
Number plate lights	incandescent	5W
Passenger compartment dome light	incandescent	8W
Spotlights	incandescent	5W
Underdoor courtesy lights	incandescent	5W
Luggage compartment lights	LED	



Replacing a fuse

When an electrical device is not working, check that the corresponding fuse is not blown.

A - Unblown fuse.

B - Blown fuse.

Important note



If the problem persists, contact the **FERRARI SERVICE NETWORK**.

Important note



When replacing a fuse, always use fuses of the same amperage (same colour).

The tool bag contains spare fuses.

To remove the fuses, use the pliers **C** in the tool bag.

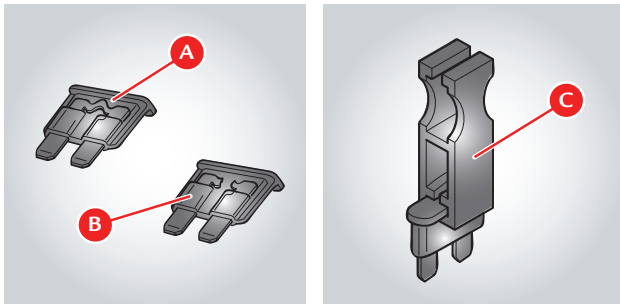

Fuse colours

	Ampere
yellow ochre	5
brown	7.5
red	10
light blue	15
yellow	20
white	25
green	30

Maxi fuse colours

	Ampere
yellow	20
green	30
red	50
blue	60



Location of the fuse and relay boxes

- A** - Fuses and relays in battery compartment
- B** - Body Computer fuses and relays
- C** - Fuses and relays in passenger compartment on passenger side
- D** - Fuses and relays on driver-side rear side panel
- E** - Fuses and relays on centre console

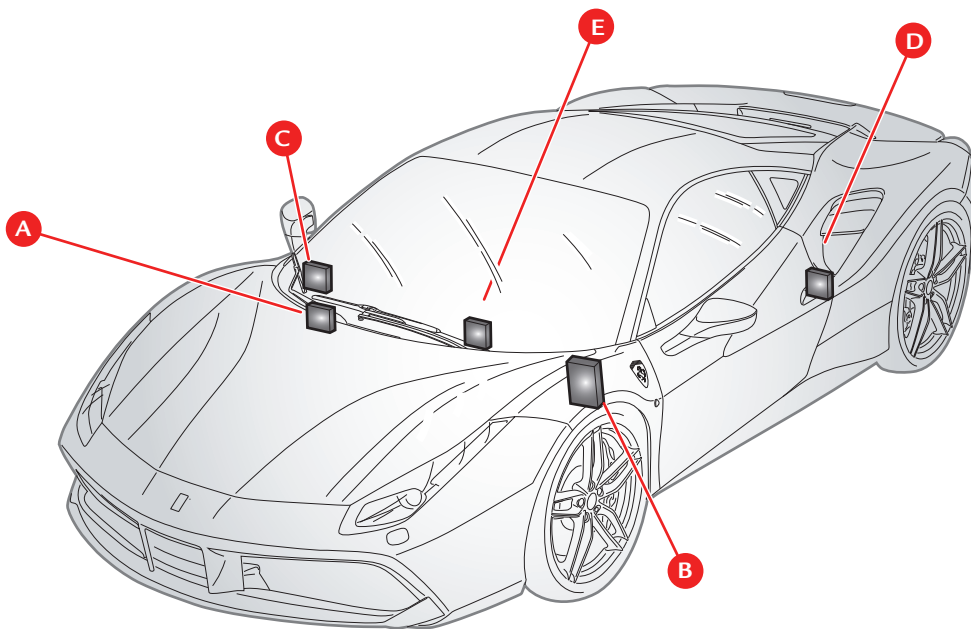



Fuses and relays in battery compartment

To access these fuses, remove the cover of the box **A** situated above the positive terminal on the right hand side of the battery.

Important note



Only open the boxes containing the fuses that need to be checked to avoid damaging other components.

Box **A** contains these fuses:

Ref.	Amp.	Use
CAL5	CAL5	Power supply (starter motor and alternator)
F-70	150	Engine relay and fuse ECU power supply (SCM)
F-71	70	Dashboard ECU power
F-72	50	Front lift pump

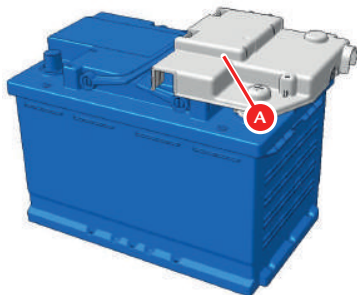

F-73	100	Centre console fuse protection
------	-----	--------------------------------

Body Computer fuses and relays

To access these fuses, remove the dashboard panel **1**.

Important note



Only open the boxes containing the fuses that need to be checked to avoid damaging other components.

Box **B** contains these fuses and relays:

Ref.	Amp.	Use
F-12	15	Right high beam
F-13	15	Left high beam
F-31	7.5	INT/A for dashboard ECU and Body Computer Node relay coils

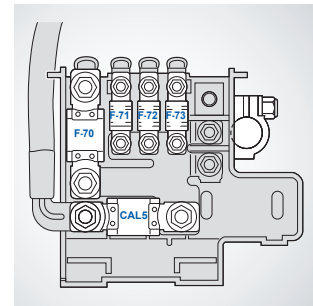



F-32	10	Puddle lights
F-33	30	Left hand Brembo EPB system motor
F-34	30	Right hand Brembo EPB system motor
F-35	7.5	+ Key for power steering, headlights, adaptive headlights, stabiliser
F-36	10	Parking sensors, fuel filler flap relay
F-37	10	Stop light control, Instrument Panel Node, Suspension Control Node
F-38	15	Luggage compartment lock actuator, parking camera
F-39	15	Dashboard ECU devices (NBC interconnection)
F-40	30	Heated rear window
F-42	15	/
F-43	30	Windscreen washer/wiper relay power supply

F-46	20	/
F-47	30	Driver-side door, driver-side power window
F-48	30	Passenger-side door, passenger-side power window
F-49	7.5	+ Key for CPOD, front lift, rear-view mirrors, active aerodynamics, parking sensors, rain sensor, electric seats
F-50	7.5	Airbag Node, weight sensor
F-51	7.5	+ Key for functions on CVB relay T21
F-52	15	Driver seat heating
F-44	20	Passenger seat heating
F-33	30	Left hand Brembo EPB system motor
F-53	10	/
T01	20	Low beam relay
T11	30	Heated rear window relay
T12	30	Service relay 1 (dependent on INT/A ignition switch)
T13	50	Jumper (service power supply 2)



- F-36 F-52 F-45 F-46 F-34
- F-39 F-41 F-47 F-33 F-48
- F-38 F-43 F-32 F-37 F-49
- F-53 F-40 F-50 F-42 F-35
- F-31 F-44 F-51 F-12 F-13

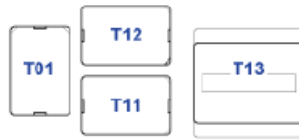



Fuses and relays in passenger compartment on passenger side

These fuses are located behind the glove compartment. The three boxes **C** contain the following fuses and relays:

Ref.	Amp.	Use
F-01	40	+30 Right hand radiator fan
F-02	40	+30 ESP9 (Pump)
F-04	40	+30 ESP9 (Hydraulic)
F-05	40	+30 Air conditioning Node
F-06	40	+30 Left hand radiator fan
F-07	20	+30 Horn relay
F-08	7.5	Air conditioning and heating system compressor
F-09	7.5	+30 Supplementary stop light relay (third stop light), luggage compartment dome light



F-10	15	30 NTP
F-11	25	Oxygen sensors
F-14	10	+30 High beam relay
F-15	7.5	+30 T19 CLA
F-16	25	/
F-17	25	Injection from T09
F-18	10	/
F-19	7.5	+30 Injection system power supply
F-20	30	/
F-21	30	+30 Key
F-22	15	Ignition coils
F-23	30	Turbine cooling fans
F-24	15	/
F-30	30	Active aerodynamics
F-81	50	+30 Fuel pump ECU

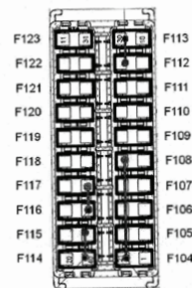



F-82	70	+30 Dashboard ECU and ECU on driver-side rear side panel power supply
F-83	50	+30 Air pump relay
F-84	15	Side markers
F-85	25	Headlight washer
F-87	25	/
F-104	15	Infotainment system, CANBOX, CD changer, clock spring
F-105	7.5	Telemetry, iNode, parking camera
F106	10	NQS rev counter
F-107	7.5	+ key for button lighting stabiliser
F-108	7.5	Central front dome
F-109	/	
F-110	/	

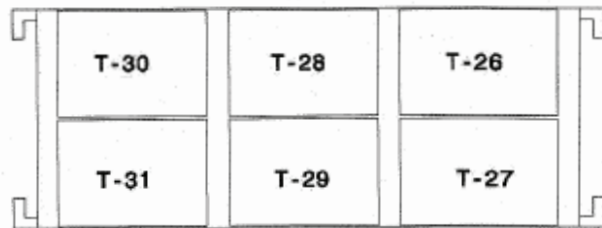

F-111	7.5	Engine ionising ECU
F-112	15	Injection system sensors
F-113	10	Turbine pumps
F-114	7.5	Front LH and rear RH side markers
F-115	7.5	Front RH and rear LH side markers
F-116	10	+30 NPE and KIN node
F-117	7.5	+30 Start-up button node
F-118	/	
F-119	/	
F-120	/	
F-121	/	
F-122	/	
F-123	/	
T02	30	High beam relay
T03	30	+15 Button lighting
T05	30	
T06	30	
T07	50	Horn relay
T08	30	Air conditioning and heating system compressor relay
T09	30	Main injection system relay
T10	30	/
T14	30	



T17	10/20	INT/A relay (devices excluded at ignition)
T19	30	Stop light control relay (CLA)
T20	30	Turbine cooling fans
T26	10/20	Windscreen wiper first speed relay
T27	10/20	Windscreen wiper second speed relay
T28	30	Windscreen washer pump relay
T29	30	Side markers
T30	30	LH DRL
T31	30	RH DRL
R3	ss	Solid state relay for third stop light
R4		+15 passive start relay

Fuses and relays on driver-side rear side panel

To access these fuses, remove the driver-side rear side panel **3**.

Boxes **D** contain these fuses and relays:

Ref.	Amp.	Use
F-54	15	/
F-55	10	+15 injection ECU, engine ionising ECU, fuel pump ECU
F-56	30	Driver Configuration Node
F-57	7.5	/
F-58	7.5	Start-up
F-59	7.5	Reverse light power supply

F-60	30	NAP
F-61	7.5	+30 Driver Position Node (electronic), front lift
F-62	7.5	Passenger Configuration Node
F-63	20	+30 Semi-automatic gearbox main relay
F-64	7.5	Fuel filler flap actuator power supply
F-65	20	+30 Door lock actuator
F-66	7.5	+30 Semi-automatic Gearbox Node
F-69	20	+15 Cigarette lighter
F-77	10	+15 Rear parking camera
F-78	30	+30 Battery charger
F-79	7.5	+15 Semi-automatic Gearbox Node
F-80	30	+30 Starting relay
T21	50	Relay for utilities with ignition switched on: engine, cigarette lighter, rear parking camera, DCT gearbox





T22	30	Reverse light relay
T23	30	Fuel filler flap relay
T24	30	/
T25	30	Electronically controlled gearbox main relay
R1		Starter power relay
R2		Starter power relay

Fuses and relays on centre console

To access these fuses, remove the flap on the centre console.

Boxes **E** contain these fuses and relays:

Ref.	Amp.	Use
F-90	30	+30 Stabiliser
F-91	40	/
F-92	40	+30 HI-FI amplifier
F-93	30	+30 Suspension control ECU

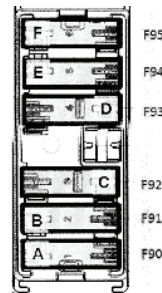
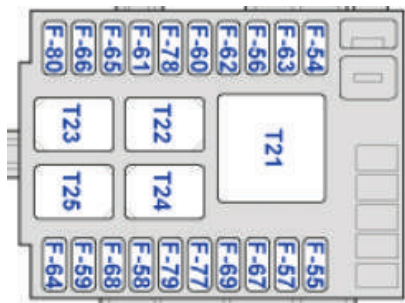



Replacing a wheel

Important note



If one or more wheels need to be replaced, proceed as follows:

- replace the wheel stud bolts with damaged threads or tapers;
- carefully clean the wheel stud bolts before fitting;
- do not lubricate the contact surfaces between the stud bolt and the wheel rim and between the wheel rim and the brake disk.

In order not to remove the antilock coating, do not clean the wheel rim cones with solvents or aggressive products.

Collapsible space saver spare wheel (optional)

On request, the vehicle comes with a kit containing:

- collapsible spare wheel **A** with space-saving tyre; label **B** indicates the maximum speed allowed of 80 km/h (50 mph);

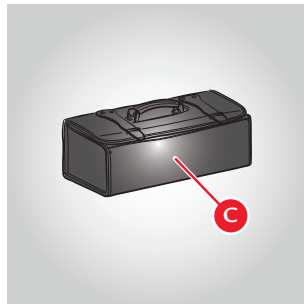
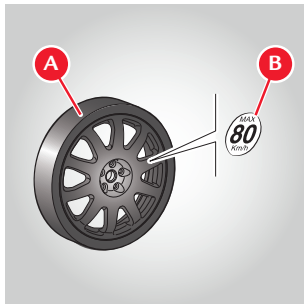

- additional tool bag **C** containing the jack for raising the vehicle and the socket wrenches for operating the jack and tightening the wheel stud bolts.

Warning



The space saver spare wheel must only be used for short trips in the event of an emergency.

When the spare wheel is fitted, never exceed the maximum speed of 80 km/h and drive carefully, especially around bends and when overtaking, avoiding sudden acceleration or braking.

Do not exceed the approved weight limits.

Do not fit snow chains on the spare wheel.

Never fit more than one spare wheel at a time.

Important note



Failure to comply with these instructions could lead to loss of control of the vehicle and consequently damage to the vehicle and injuries to its occupants.



Replacing a wheel

- Position the vehicle on an even surface, then block the rear wheels by applying the parking brake.

Warning



Make sure that the vehicle is in a safe position by applying the parking brake.

- If necessary, switch on the hazard warning lights and place the hazard triangle at the required distance from the vehicle.
- Take the spare wheel and tools out of the luggage compartment.
- Loosen the five wheel stud bolts approximately one turn each using wrench **D** supplied.
- Place the base of the jack **E** on flat firm ground under one of the jacking points **F** on the underfloor as shown in the figure.

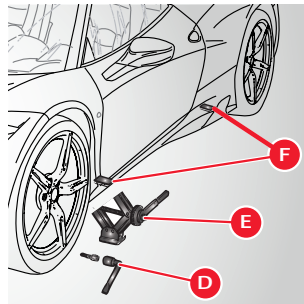

- Raise the vehicle carefully using jack **E** until the wheel is off the ground.

Warning



If the jack is not positioned correctly, the vehicle could slip off. Make sure that no part of the body is underneath the vehicle while changing the wheel.

The supplied jack must only be used for changing wheels.

- Unscrew the five stud bolts and remove the wheel.
- Fit the uninflated collapsible spare wheel.
- Screw the stud bolts into place but do not tighten them.

Warning



Inflate the collapsible spare wheel before lowering the vehicle to avoid damaging the rims.

- Inflate the collapsible spare wheel using the inflation kit.

4



Warning



The kit must be used in “tyre inflation” mode. Refer to the instruction manual supplied with the kit.

- Inflate the spare wheel to the indicated pressure (see page 29).
- Lower the vehicle and remove the jack.
- Tightly fasten the stud bolts, alternately going from one stud bolt to one that is diametrically opposite.

As soon as possible, tighten the stud bolts with the torque wrench to a torque of 100 Nm.

Warning



The space saver spare wheel does not have a tyre pressure monitoring sensor (see label on spare wheel tool bag). After fitting, it is not checked by the system but complies with international regulations ECE R64/01.

After fitting, we recommend that you go to the nearest FERRARI SERVICE NETWORK.

Towing

When towing the vehicle, avoid using anchor points that are not designed for tow hook **A** inserted in housing **C**.

Proceed as follows:

- Take tow hook **A** out of the tool bag.
- Screw the tow eye **A** fully into the threaded hole **C** in the front bumper.
- Release the EPB.
- Release the Park Lock.

Warning



In the event of an electrical system failure, release the EPB and Park Lock manually (see pages 232-234).

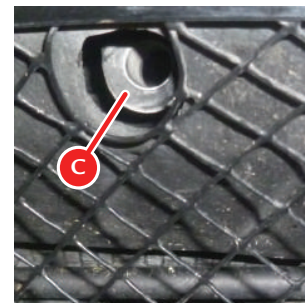
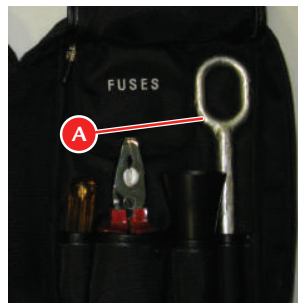



Warning



While towing the vehicle, you must comply with Road Regulations.

Warning



Do not tow the vehicle by attaching to levers, suspension and wheel rims but only to the tow hook properly fitted in place. Keep the instrument panel activated to enable the lights to work; when towing the vehicle, do not start the engine.

Important note



Remember that when the engine is switched off, the power steering and brake servo functions do not work.

Fuel inertia switch

The fuel inertia switch is a safety device which deactivates the fuel pump relays if a collision occurs.

A symbol appears on the left TFT display and the hazard warning lights come on to indicate that the switch has been activated.

When the fuel inertia switch is activated, the doors are also unlocked (if locked) and the central dome light comes on.

Warning



The fuel pump relays can be reactivated by pressing the button in the battery compartment which can be accessed by opening the passenger side footrest.

4





Battery

The battery is located in the passenger compartment behind the passenger side footrest.

Checking the battery

Warning



The battery does not need topping up with distilled water or sulphuric acid.

Warning



The battery must only be removed from the vehicle by the FERRARI SERVICE NETWORK.

Warning



Do not place the battery near sources of heat, sparks or naked flames.

The vehicle is equipped with a sealed lead acid battery that does not require maintenance.

- Periodically check that the terminals and pins are clean and firmly secured.
- Visually inspect the outer casing for any cracks.
- If the battery overcharges, it will wear out quickly. Have the vehicle electrical system checked if the battery tends to discharge easily.

Disconnecting the battery

Before disconnecting the battery, deactivate the electronic alarm using the remote control.

Warning



Never disconnect the battery from the electrical system when the engine is running.

Before disconnecting the battery, lower the side windows by at least 2-3 centimetres to avoid damaging the strips when opening and closing the doors.

Warning



When the battery is connected and charged, this operation is automatically performed when the doors are opened and closed. The windows must remain lowered until the charged battery is reconnected. If the battery is discharged and the windows are fully up, only open the doors when strictly necessary and take great care; do not close them again until the windows can be lowered.

Important note



We recommend using the battery conditioner if the vehicle is going to left unused for a long period.

To cut off the power supply from the battery to the electrical system, use the quick release **C** terminal on the left hand side of the battery. Use the locking lever to loosen the terminal.



Detach the terminal from the battery and place it on hook **D**. In this way, the power supply from the battery to the electrical system is cut off.

Warning



The battery quick release connector may only be used by qualified personnel, should it not be possible to connect the battery conditioner.

The battery is an integral component of the vehicle, and required the vehicle itself to be used frequently in order to function correctly. Infrequent vehicle usage may reduce battery performance or result in complete battery failure.

Constant usage of the specific battery conditioner provided by FERRARI for each model ensures that the original battery installed in the vehicle is kept charged correctly and in working order.

Warning



Place the terminal so that it does not come into contact with the battery terminal or other metal parts of the vehicle.

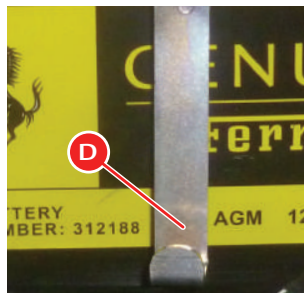
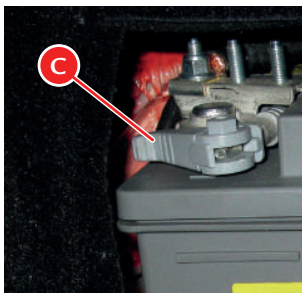

Reconnecting the battery

Take the terminal off hook **D**, place it on the battery and fasten it by closing the locking lever.

Each time the battery is reconnected, do the following before starting the engine:

- close both doors and close the luggage compartment lid; unlock and lock the doors using the remote control; open the luggage compartment lid using the remote control;
- adjust the clock (date and time on instrument panel);
- close both doors and fully raise the driver side and passenger side windows to their upper limit; check that the windows move down to the "target position" when the doors are opened.

Warning



4

Before starting the engine, wait at least 60 seconds after activating the instrument panel to allow the electronic system that controls the motor-driven valves and the AC ECU to run a self-acquisition process.

During this period, no devices must be activated.

The Motronic ECU self-acquisition cycle will only function correctly when the intake air temperature is above 5 °C (41 °F).

After removing the battery from the vehicle or disconnecting it from the electrical system using the battery master switch, it is important to check that the external temperature is within the indicated values when reconnecting before performing the self-acquisition cycle.



Emergency starting

If the battery is flat, you can perform an emergency start by connecting the special jump leads to the battery of another vehicle, a portable jump starter or an external battery.

Important note



Emergency starting can only be performed with batteries with a nominal voltage of 12 V.

Important note



For emergency starting, only use leads that do not allow reverse polarity, with sufficient cross-section and insulated clamps.

To perform an emergency start, do the following:

- Apply the parking brake.
- Deactivate all the electrical devices.
- Remove cover **A** of the fuse box located above the positive terminal on the right side of the battery.
- If emergency starting is performed using the battery of another vehicle, leave the engine on the other vehicle to idle.
- Using the jump leads, connect the positive terminal of the battery to the positive terminal of the portable jump starter or external battery going from the battery on your own vehicle.
- Connect the negative terminal of the portable jump starter or external battery to an earthing point on your vehicle using the jump lead going from the external battery.
- Start the engine.
- Disconnect the jump lead from the earthing point and then from the positive terminal of the battery on your vehicle.

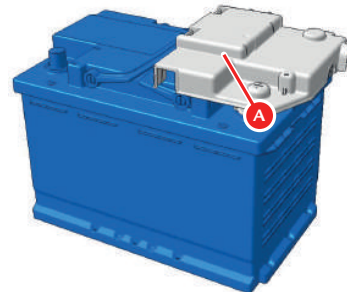



Warning



The emergency start procedure must only be performed by a specialised FERRARI SERVICE NETWORK centre.

4



Battery conditioner

The vehicle is equipped with a battery conditioner to maintain and recharge the battery.

Important note



If a battery is not periodically maintained, it will be subject to an irreversible loss of functionality. The time taken to reach this state depends on the battery charge level and we therefore recommend that you always use the battery conditioner when parking for over 70 hours.

The device is kept in a pocket inside the car cover bag supplied with the vehicle. The socket for the battery conditioner is installed at the back of the vehicle on the luggage compartment lid next to the number plate light.

Connection is via a magnetic coupling.



Warning



Place the battery conditioner where it can be easily seen away from heat sources and out of children's reach.

If the car is going to be left unused for periods longer than one week, we recommend that you connect the battery conditioner in order to keep the battery in good working order.

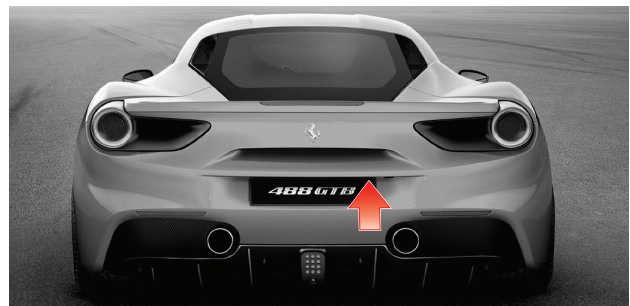



Warning

To avoid damaging the conditioner and vehicle, always disconnect the magnetic coupling before starting the vehicle.

Important note

Additional more detailed technical and safety information on use of the device can be found in the “BATTERY CHARGER” leaflet supplied with the vehicle.

Exhaust system overheating alarm devices (“Slow Down” function)

If the engine is running unevenly resulting in exhaust system overheating, the “Slow Down” function is activated: a special symbol (see page 106) appears on the left TFT display accompanied by a message.

The message varies according to three alarm levels:

- **Temperature high:** “Catalysts temp. high. Slow down”.
- **Temperature too high:** “Catalysts temp. too high. Engine performance limited”.
- **Catalytic converter temperature system failure:** “Catalysts temp. not plausible. Go to dealer slowly”.

Displaying of the message is controlled by the thermistor via the engine control ECU.

4

Warning

Incorrect use of the vehicle may cause the “Slow Down” function to be activated.

Warning

If the temperature is **high**:
slow down immediately so that the exhaust system temperature decreases.



Warning



If the temperature is **too high**: the temperature in the catalytic converters has reached a dangerous level and could damage them; if you continue to drive, the engine control ECU intervenes and reduces the torque produced by the engine.

The torque limit remains active until the catalytic converter temperature goes down to normal operating values.

Warning



If catalytic converter temperature system failure information is displayed:

- the engine control ECU intervenes and reduces the torque produced by the engine;
- the driver must slow down and slowly drive to the nearest FERRARI SERVICE NETWORK to have the engine parameters checked.

Warning



If the EOBD warning light (see page 105) comes on at the same time as the “Slow Down” message, go to the nearest FERRARI SERVICE NETWORK to have the ECU error memory checked. Do not proceed in any other way.

Clutch overheat alarm devices

Extremely high performance use of the vehicle at high engine speeds for prolonged periods and at high ambient temperatures may cause the DCT gearbox clutches to overheat. In this case, the following safety warnings will be displayed on the left TFT display, corresponding to two different alarm levels:

- The message “Clutch overheated”.
- The message “Clutch overheated” accompanied by an acoustic signal.

When the message “Clutch overheated” is displayed, the driver may notice a difference in the behaviour of the system during gearshifts and/or during standing starts.

Important note



Certain high-performance actions (including but not limited to: “LAUNCH” control start, standing start with wheelspin with Manettino set to ESC OFF, etc.) may be inhibited to prevent excessive overheating of the clutches: the system warns the driver that the action is not permitted by displaying the message “Operation not admissible” on the left TFT display.



Warning



As soon as any of the warnings described above appear on the left TFT display, the driver must slow down, continue driving at an engine speed between 2000 and 3000 rpm and minimise gearshift frequency to allow the clutches to cool down as quickly as possible. These driving conditions must be maintained until the message “Clutch overheated” is no longer displayed.

Engine malfunction alarm devices

If the “engine control system failure” (EOBD, see page 105) warning light flashes or comes on permanently while the engine is running, it indicates that the engine or the emission control system may be malfunctioning.

The electronic system detects and isolates the error preventing damage to the engine or the production of harmful emissions.

Warning



When the “engine diagnostic system failure” warning light comes on, engine performance may be considerably reduced. Drive carefully, avoiding sudden acceleration and high speeds. Contact the **FERRARI SERVICE NETWORK** immediately.



Replacing the brake pads and discs

Brake pads

The front brake pads have a wear detector connected to the brake warning light; if this warning light comes on or braking is not even, have the pad thickness and the state of the braking surfaces checked.

The minimum brake pad thickness is 3 mm (thickness of the friction material only).

Replacing brake pads

When the brake failure warning light comes on, it means that the front brake pads are excessively worn and must be replaced immediately.

Warning



To guarantee the quality of the components and proper installation, we recommend that you have the brake pads replaced at a **FERRARI SERVICE CENTRE**.

After replacement, avoid sudden braking until the new pads are seated properly (approximately 300 km).

Emergency release of the electric parking brake (EPB)

Warning



The release procedure must only be carried out by specialised workshop technicians and with the vehicle switched off.

If the system cannot be released, contact the nearest **FERRARI SERVICE CENTRE**.

Warning



When the electric parking brake is deactivated manually, the vehicle may move.

To keep the vehicle stationary, the Park Lock safety device must be applied: make sure that the letter "P" appears on the gearbox display.

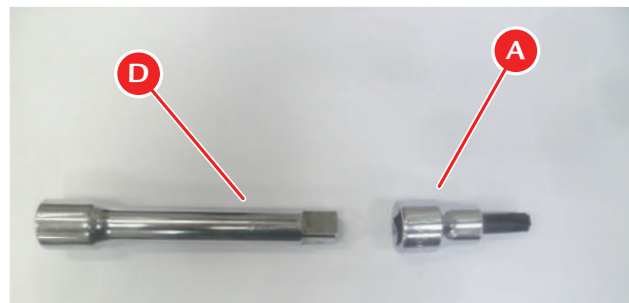



If the electric parking brake cannot be deactivated because the battery is flat or there is a failure in the electrical system controlling it, and the vehicle needs to be moved, the emergency release procedure described below must be performed.

- Before performing this procedure, remove fuse F33 and F34 from the body computer fuse box, situated under the driver side of the dashboard (see page 215).
- Select the EPB emergency release socket wrench **A** from the tool bag and connect to the extension **D**

Warning



The EPB emergency release tool **A** may only be used by specialised workshop technicians, as indicated on label on the tool bag.

- The EPB system components are situated over the right and left hand rear callipers: Insert the EPB release tool **A**, connected to the extension **D**, through the access holes **B**. Insert a standard 1/2" wrench from the opposite end of the extension **D** and turn anticlockwise by two turns to free the brake discs.

Warning



Never loosen the screws completely.

Once the electric parking brake has been manually released, the EPB node records a failure at the next key-on and a special symbol and the following message are displayed on the left TFT display: "Parking Brake system revision. Go to dealer".

Warning



If access to the screws is obstructed by a wheel spoke, the wheel must be removed.

The EPB release procedure is irreversible and compromises the functionality of the parking brake.

Take the vehicle to an authorised service centre to have the parking brake reset correctly and cancel any errors from the fault memory.

Go to a FERRARI SERVICE CENTRE.

For safety reasons, the reset procedure is mandatory.

4

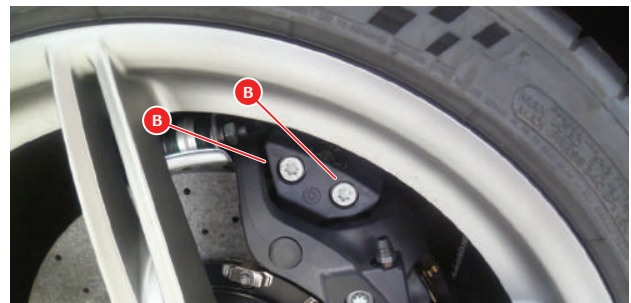



Park Lock emergency release

Warning



The emergency release procedure must only be carried out by specialised workshop technicians.

If the system cannot be released, contact the nearest **FERRARI SERVICE CENTRE**.

Warning



This should be avoided unless absolutely necessary:

- to tow the vehicle;
- if there is a Park Lock failure (displayed on the left TFT display with the message “Only manual unlock gearbox allowed: See handbook”).



Warning



When the Park Lock safety device is deactivated manually, the vehicle may move unexpectedly.

The vehicle is only kept stationary by the parking brake, if applied.

The Park Lock manual emergency release device is found in the engine compartment near the gearbox, as shown by the arrow in the figure.

To perform the Park Lock emergency release procedure, do the following:

- Take wrench **D** and the extension **E** out of the tool bag.

Warning



Wrench **D** may only be used by specialised workshop technicians, as indicated on label **C** on the tool bag.

- Open the engine compartment lid.



- Extend wrench **D** using the extension **E** and place it in the manual release device housing.

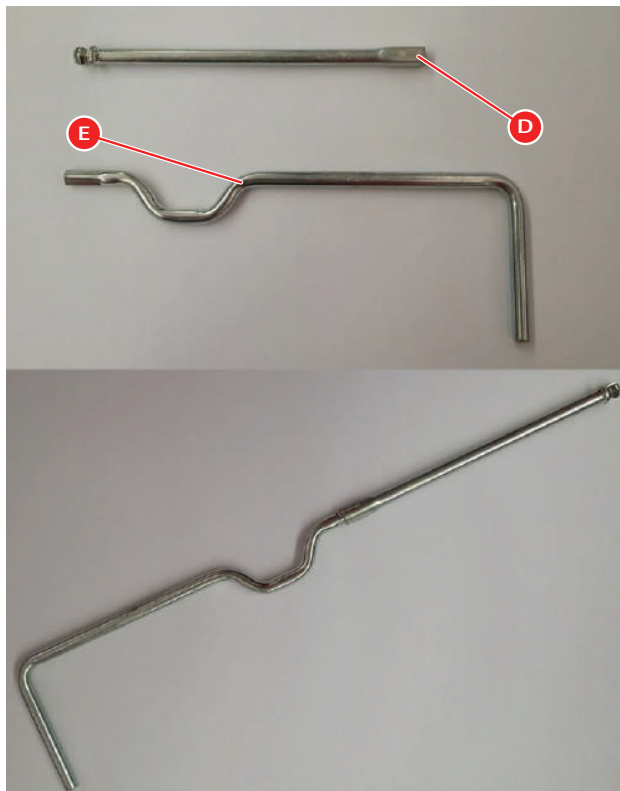

Important note



Make sure that the notch on wrench **D** fits onto the pin in the device housing.

- Once the wrench has been placed in the housing, lightly press down on the filter housing to bring the wrench at right angles to the housing.
- To perform the emergency release, turn wrench **D** counterclockwise for a quarter turn.

If the electrical system allows it, check that the letter “N” appears on the gearbox display by activating the instrument panel. The following message will appear on the left TFT display: “Gearbox not in Parking position”. At the same time, an audible signal is repeated four times to indicate that it has been released.

4

Warranty Booklet	238
Maintenance	238
Level checks.....	240
Wheels and tyres	247
Maintenance of seat belts and pretensioners.....	249
Cleaning the vehicle	249
If the vehicle is stored for long periods.....	253



CARE OF THE VEHICLE



Warranty Booklet

The vehicle comes with a “Warranty Booklet”.

This contains the vehicle’s warranty validity conditions.

Maintenance

It is essential to always keep the vehicle in proper working order to ensure a long working life and to prevent any running defects, caused by negligence or lack of maintenance, and consequently to avoid hazardous situations.

Important note



All repair work on any safety system component must be performed by the FERRARI SERVICE NETWORK. See the chapter on safety, page 40.

Maintenance schedule

At the intervals prescribed, the FERRARI SERVICE CENTRES must perform all the fine-tuning and checking operations indicated in the “Warranty Booklet”.

It is however advisable to report any small fault which occurs when using the vehicle (e.g. small leaks of essential fluids) to the FERRARI SERVICE NETWORK immediately and not wait until the next service is due to correct the problem.

Periodic maintenance services must be performed at least once a year even if the specified mileage limit has not been reached (see “Yearly Maintenance” in the “Warranty Booklet”).

Displaying information on scheduled maintenance

If the next scheduled maintenance deadline is approaching, at key-on, the message “Service Stop within:” is displayed for 5 seconds on the left TFT display followed by the number of kilometres or days before vehicle servicing. The information is provided in kilometres or days according to the deadline that comes first.

Information on scheduled maintenance can also be displayed on the left TFT display if requested by the driver irrespective of the scheduled deadlines. To do this, call up the MENU screen page (see page 86) and select “Service”.



Chassis and bodywork maintenance

The chassis has technological and manufacturing specifications that require that any operation be performed by staff specially trained to work with this innovative technology.

It is of crucial importance to use equipment tested by FERRARI if the repair work is to be performed in accordance with rules of good workmanship. Proper execution of repair work ensures that the commercial value of the vehicle is preserved and the safety standards are complied with.

Important note



If the chassis is damaged in an accident, FERRARI advises customers to contact the FERRARI SERVICE NETWORK who will perform the necessary safety checks.

The chassis, under standard conditions of use, requires no maintenance; it is however advisable to contact the FERRARI SERVICE NETWORK at the intervals indicated in the “Warranty Booklet” in order to have it checked.



Level checks

Ref.		Page	Ref.		Page
A	Engine oil tank cap	242	D	Brake fluid tank cap	245
B	Coolant tank cap	244	E	Windscreen/headlight washer fluid tank cap	246
C	Power steering oil tank cap	244			

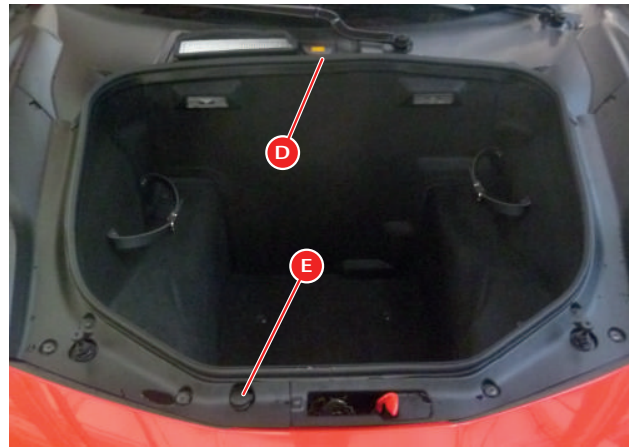
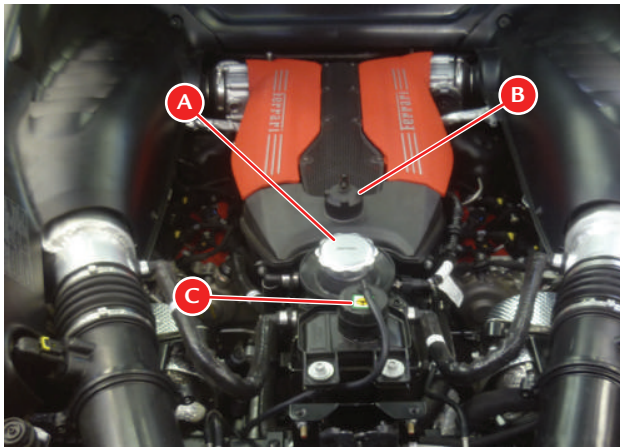



Important note



The level checks must be performed at the intervals indicated in the “Warranty Booklet” or, in any case, before starting a long journey.

Environment



All the materials used for the following operations (e.g. cloths soaked with oil or grease, pans, etc.) must be disposed of in compliance with the environmental protection regulations.

Important note



Only use lubricants and/or fluids recommended by FERRARI or, in any case, that comply with the specifications defined by FERRARI (see the “Refilling” table on page 38).



Checking the engine oil level

Warning



The engine oil level must be checked when the engine is idling and warm and the vehicle is on level ground.

DO NOT add oil with different characteristics from those of the oil already in the engine.

The symbol, shown below, on the left TFT display and the message “Low engine oil pressure, stop and turn off engine” indicate that the driver must stop and check the engine oil level.



Proceed as follows:

1. Run the engine to reach an engine oil temperature of 90 °C (194 °F).
2. Let the engine idle and check that the air conditioning is OFF.
3. Wait 2 minutes and then open the engine compartment lid and unscrew the oil tank cap **A**.
4. Clean the dipstick on the cap.
5. Place the cap **A** on the tank filler neck, with the cap spring in its seat as shown in detail **M**.
6. Remove the cap and check that the level is between the **MIN** and **MAX** notches on the dipstick.

Important note



The distance between the **MIN** and **MAX** notches corresponds to approximately 1.5 litres of oil.

7. Top up if necessary with the recommended oil, taking care not to fill beyond the **MAX** level on the dipstick.

Warning



If the oil level is below **MIN**, top it up and then have the system checked by the **FERRARI SERVICE NETWORK**.

8. Screw the cap back on tightly.





After topping up, the “low oil level” symbol on the left TFT display may remain on for some time. This will allow the system to perform all the necessary checks. You should therefore consider this behaviour normal.

9. When you have added or changed the oil, check the oil level once again as indicated above.

Environment



Top up with due care to avoid pouring the oil out of the filler neck.

Checking the DCT gearbox oil level

Important note



We recommend that you have the oil level of the DCT gearbox checked by the FERRARI SERVICE NETWORK or by skilled staff.

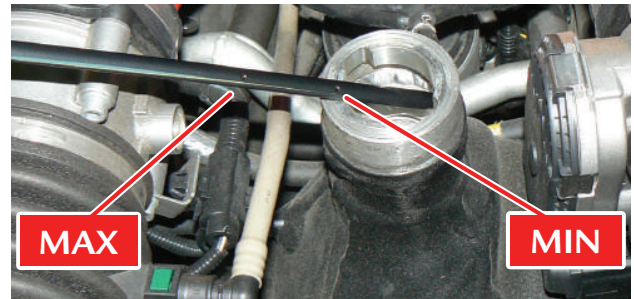
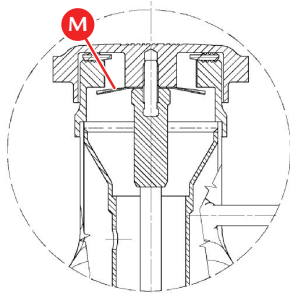

5



Checking the coolant level

Warning



The coolant in the cooling system reaches very high temperatures and pressures. This procedure must always be performed when the **ENGINE IS COLD**. **Never** remove the cap from the expansion tank when the engine is running or warm.

- If the level is low, remove the cap **B** from the expansion tank and top up with the recommended coolant.

Important note



If frequent top-ups are required after short trips, have the system checked by the **FERRARI SERVICE NETWORK**.

- Screw the cap **B** back on tightly.



Checking the power steering system oil level

Warning



The power steering oil level must be checked with the engine warm, after having driven at least 15 km. If it is checked when the engine is cold, the level may appear to be very low even when the recommended amount of oil is in the system.

Warning



If the oil level is below **MIN**, top it up and then have the system checked by the **FERRARI SERVICE NETWORK**.

Proceed as follows:

- Remove cap **C** with the dipstick from the tank.

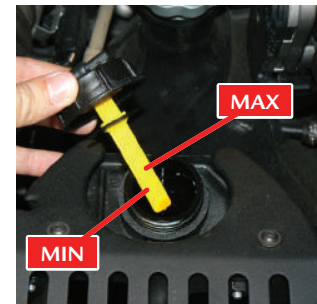
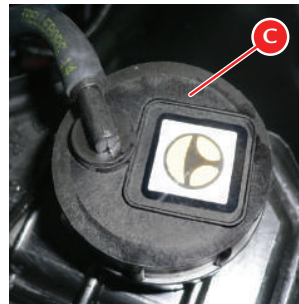



- Check that the power steering oil level is between the **MIN** and **MAX** levels on the dipstick.
- If the level is near the **MIN** reference mark, top up with the recommended oil up to the **MAX** level.

Warning



Always use the indicated quantity of new, recommended fluid taken from sealed containers.
The fluid in the circuit is synthetic. The use of mineral-based fluid may irreparably damage the rubber system gaskets.

- Screw the cap **C** back on tightly.

Environment



Do not dispose of used fluid in the environment.

Checking the brake fluid level

The brake fluid tank is located under the right-hand under-windscreen protective cover. Proceed as follows:

- Remove cover **P**, remove cap **D** and check that the fluid is near the **MAX** mark shown in the figure.

Important note



Clean cap **D** before removing it.

- If the level is near the **MIN** mark shown in the figure, top up with the recommended oil to the **MAX** mark.

Warning



Always use the indicated quantity of new, recommended fluid taken from sealed containers.

5

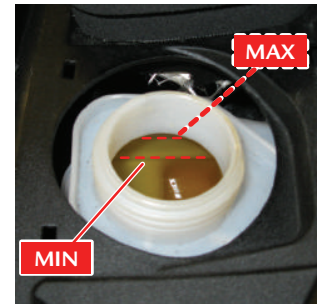
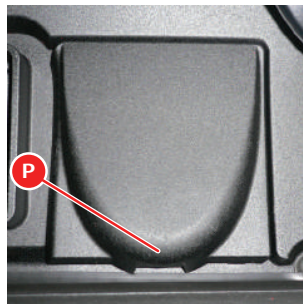



Environment



Never dispose of used fluid in the environment.

Warning



The fluid in the brake system may damage plastic, rubber and painted parts and is highly dangerous if it comes into contact with the eyes or the skin.

If the fluid comes into contact with the eyes or skin, wash the affected part thoroughly with running water. To avoid any risk, always use protective goggles and gloves.

Keep out from children's reach!

Warning



The use of mineral-based fluids will irreparably damage the system rubber gaskets.

Do not use fluids other than those already in the system for topping up.

- Screw cap **D** back on tightly.

Windscreen and headlight washer fluid

The windscreen and headlight washer fluid tank can be accessed by lifting the luggage compartment lid.

- Lift the cap **E** and fill the tank with the recommended fluid (see the “Refilling” table on page 38) until it can be seen in the fluid filling manifold.
- Close cap **E**.

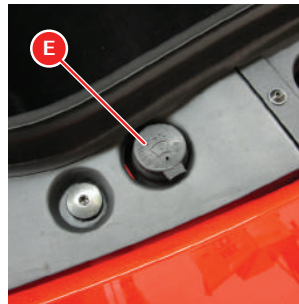



Wheels and tyres

To ensure maximum performance and tyre life and to permit the best tyre adjustment on the wheel rim, it is important to comply with the following instructions for the first 200/300 km with new tyres:

- avoid sudden acceleration;
- avoid sharp braking and steering;
- drive at moderate speed on straight roads and on curves.

How to use the tyres

Important note



To ensure safe driving, the tyres must be kept in good condition.

The inflation pressure must correspond to the specified values and must be checked only when the tyres are cold since tyre pressure increases as tyre temperature increases.

Never reduce the pressure if the tyres are hot.

Environment



Periodically check the tyre pressure. Driving with the tyres inflated to the correct pressure helps to reduce fuel consumption.

Low tyre pressure can lead to overheating, internal damage and even destruction of the tyres.

Warning



Inflating the tyres to a pressure other than the specified value will render the TPMS monitoring system ineffective.

Sudden impact with pavements, potholes and other obstacles of various types as well as long trips on rough roads can cause damage to the tyres that is not always visible to the naked eye.

Check the tyres regularly for any signs of damage (e.g. scratches, cuts, cracks, bulges, etc.).

If sharp objects penetrate the tyres, they can cause damage which is only visible when the tyre is removed.

Have any damage inspected by an expert as it may considerably reduce tyre life.

Remember that tyres deteriorate over time even if they are rarely used or not used at all.

Cracks in the tread and side walls, possibly accompanied by bulging, are sure signs of ageing.



Warning



The FERRARI SERVICE NETWORK is suitably equipped to replace tyres, and to determine whether a tyre is safe for use. Only have the tyres replaced by the FERRARI SERVICE NETWORK which has the necessary equipment since careless handling may damage the sensor inside the wheel rim.

Important note



The FERRARI SERVICE NETWORK can certify whether aged tyres are suitable for use.

Warning



Replace the tyres at intervals no longer than 4 years of normal usage, even if the maximum mileage specified has not been exceeded.

Never fit tyres of uncertain origin.

Warning



The tyres are of the “directional” type and there is an arrow marked on their side wall to indicate the direction in which they must rotate or which side is the outer side. When replaced, maximum performance levels can only be ensured if the rotation direction corresponds with the direction indicated by the arrow. Tyres on the same axle must always be replaced in pairs.

Regularly check the tyre tread (minimum acceptable depth **1.7 mm**). As the tread wear increases, there is a greater risk of skidding.

Warning



Drive carefully on wet roads to reduce the risk of “aquaplaning”.

Wheel alignment check and adjustment

When you notice unusual wear of the tyres and in any case, at the intervals prescribed in the “Warranty Booklet”, have the FERRARI SERVICE NETWORK check the wheel toe-in and camber.



Maintenance of seat belts and pretensioners

- Periodically check that the screws on the anchor points are tight and that the seat belt is in perfect condition and slides smoothly.
- The seat belt must be kept clean; the presence of any dirt could prevent the seat belt retractor from working properly.
- To clean the seat belt, wash it by hand with mild soap and water, rinse it and let it dry. Do not use strong detergents, bleach or aggressive solvents, as they can weaken the fibres.
- Do not let the seat belt retractors get wet: proper functioning is only ensured if they are kept dry.
- The pretensioner requires no maintenance or lubrication. If immersed in water or mud, the pretensioner must necessarily be replaced.
- The pretensioner must be replaced at the intervals indicated in the “Warranty Booklet”.

Cleaning the vehicle

Cleaning the exterior

Environment



All the materials used for the following operations (e.g. cloths soaked with oil or grease, pans, etc.) must be disposed of in compliance with the environmental protection regulations.

Proper care of the vehicle on the part of the owner is essential for the vehicle long life.

Here is a list of the main precautions to be taken:

- Certain parts of the vehicle should not be left wet or dirty for long periods of time: in particular, the passenger compartment floor and the luggage compartment must always be kept clean and dry. The draining holes under the doors should be kept unclogged to allow any water to drain.
- The underbody and the lower surfaces of the vehicle should be cleaned regularly, and more frequently (at least once a week) if the vehicle is used on salty or rough roads. The vehicle should be cleaned thoroughly and carefully: cleaning that merely wets encrusted mud without removing it completely can prove damaging.
- The vehicle must be washed regularly with suitable equipment. Do not use very hot water or steam to clean the paintwork and the lower surfaces. It is advisable to soften any dirt first, then remove it with a jet of water at room temperature.

5



Important note



Do not use aggressive products for cleaning the windows. The use of aggressive products could seriously damage the bodywork.

- Do not wash the vehicle in direct sunlight or when the bodywork is still warm: make sure that the jet of water does not blast the paintwork; wash the vehicle with a sponge and a mild soap and water solution; rinse the vehicle again with a jet of water and dry it with a chamois leather.

Important note



When the vehicle has been washed, apply slight pressure to the brake pedal at moderate speed before driving at a normal speed, until the brake discs and pads have cleaned off.

In order to maintain the shine on the paintwork, polish it once or twice a year with products recommended by FERRARI.

- Any areas that are cracked or chipped by stones, scratches or parking manoeuvres, etc., must be immediately repaired by the FERRARI SERVICE NETWORK.
- Do not park the vehicle in damp and/or unventilated areas for long periods of time.

Cleaning and care of matt paintwork (optional)

Warning



The paintwork **MUST NOT** be polished using any type of product.

Owners must take great care of vehicles with matt paintwork (optional).

Here is a list of the main precautions to be taken:

- Wash the vehicle using a steam cleaner and rinse with demineralised water only.
- It must be dried using an automatic dryer or compressed air. Manual drying can **ONLY** be performed using a clean 3M microfibre yellow cloth that has been soaked in demineralised water in the areas where limescale deposits are present. The cloth must be kept in a special clean container.
- To clean any grease or oil marks, a clean 3M microfibre yellow cloth soaked in R107/S solvent (heptane) can be used. A new cloth must be used and it must not have been previously soaked in demineralised water.
- Do not wash the car in direct sunlight.
- Wash the vehicle only when the bodywork and engine are cold.
- Do not apply stickers to the bodywork.



- Any areas that are cracked or chipped by stones, scratches or parking manoeuvres, etc., must be immediately repaired by the FERRARI SERVICE NETWORK.

Important note



DO NOT lean against the vehicle especially if you are wearing clothes with buttons, buckles or are wearing rings, necklaces, etc. This may cause irreparable damage to the bodywork.

Important note



To use suitable products, contact the FERRARI SERVICE NETWORK.

Cleaning of protective anti stone-chipping film (optional)

The film has been designed to protect the bodywork: anything that damages the paint will also damage the film.

Warning



Do not pour denatured ethyl alcohol, acetone, isopropyl alcohol, heptane or substances that contain these compounds on the film.

- Do not apply adhesive elements on the film.
- When cleaning, do not use metal or abrasive substances in general and acid chemical compounds.

Important note



Avoid the film coming into contact with the brake fluid: the film will become opaque.

- Do not use solvents along the edges of the film to them from penetrating inside the adhesive layer.

Important note



Nürburgring Silver, Avus White, Alloy Grey, Met Avio, Ivory, Met Light Blue, Met Sky-Blue and Fuji White vehicles must be washed every month and waxed at least twice a year so that dirt, acid rain, pollutants, etc. do not penetrate the pores of the film and cause it to tarnish.

Important note



We recommend replacing the film every 24 months for vehicles in Nürburgring Silver, Avus White, Alloy Grey, Met Avio, Ivory, Met Light Blue, Met Sky-Blue and Fuji White, as the finish quality may deteriorate slightly (yellow tarnish) due to dirt accumulated in the porous surface of the film.

It should be noted that timely and accurate cleaning (monthly washing and waxing twice a year at least) will prevent deterioration of the film.

5



Cleaning the interior

Cleaning and care of the leather upholstery

As indicated in the “Maintenance Schedule” (see the “Warranty Booklet”), proper and regular treatment, at least once a year, will help preserve the quality, natural characteristics and softness of the leather upholstery in your FERRARI.

With this in mind, specific leather care products are also available (“Cleaner” and “Cream”) both tested by FERRARI.

These products can be ordered through the FERRARI SPARE PARTS SERVICE DEPARTMENT, both individually and as part of the “Care Kit” which includes the complete range of products for cleaning the vehicle.

Important note



For use of the “Care Kit” products, contact the FERRARI SERVICE NETWORK.

The following products must be avoided when cleaning the leather: harsh detergents, turpentine, liquid stain removers, petrol, solvents and domestic cleaning products. All of these products damage the natural material.

Cleaning and care of the Alcantara® upholstery

Warning



Do not use steam cleaners.

- Carefully dust the parts to be cleaned.
- Use a soft cloth or sponge moistened with clean water.
- Thoroughly wring out the cloth and wipe it over the entire Alcantara® area making sure you do not overwet it.
- Repeat the procedure.
- Let it dry completely.
- To recondition the material, gently use a brush with soft bristles.



If the vehicle is stored for long periods

If the vehicle is not used for long periods of time, certain precautions should be taken:

- if possible, park the vehicle on a level surface in a covered and well-ventilated area;
- prevent the vehicle from moving by engaging a gear;
- bring the tyre pressure to 3.0 bar and periodically change the point where the tyres rest on the ground;
- connect the battery conditioner (see page 198);
- protect the vehicle with a breathable fabric cover and avoid materials that prevent any dampness on the bodywork from evaporating.

Before using the vehicle again after long periods of inactivity, adjust the tyre pressure to the indicated pressure and check the fluid levels of all the systems.

Important note



If you do not intend to connect the vehicle to the battery conditioner, the battery must be recharged at least once every two weeks to keep certain functions, such as the radio station memory, alarm system, etc., working correctly.

The battery is an integral component of the vehicle, and requires the vehicle itself to be used frequently in order to function correctly.

Infrequent vehicle usage may reduce battery performance or result in complete battery failure.

Constant usage of the specific battery conditioner provided by FERRARI ensures that the original battery installed in the vehicle is kept charged correctly and in working order.

Glossary..... 257

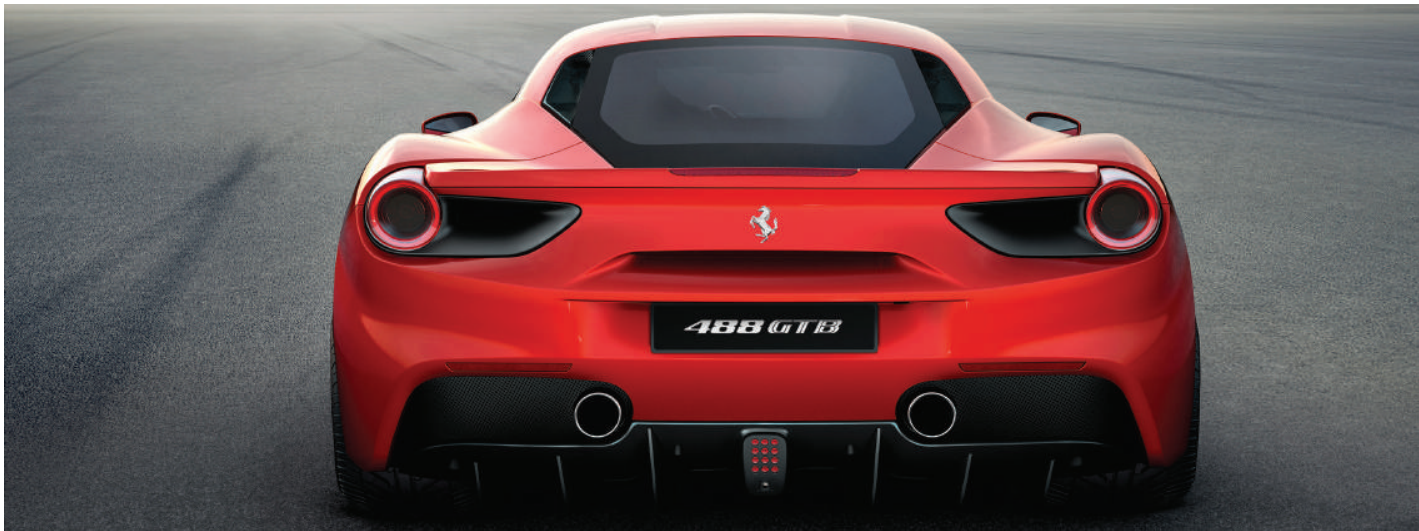

GLOSSARY





Abbreviation	Meaning
ABS	(Anti-lock Braking System) The ABS prevents wheel locking when braking so that vehicle handling can be maintained.
AC	Air conditioning
ASR	(Antriebs Schlupf Regelung) Anti-skid regulation during acceleration.
Auto easy exit	Simplified function gear shifting. To exit “Auto easy exit” mode, simply operate one of the two shift paddles.
Autopark	Automatic activation of the electric parking brake (EPB) when the engine is switched off. This function can be disabled.
AVH	Automatic Vehicle Holding Additional function of the electric parking brake (EPB): it allows gradual release of brake shoes/pads when the vehicle starts up. This guarantees an optimised release for the vehicle and is an aid for the driver.
DCT	Dual Clutch Transmission Each clutch is associated with a part of the gearbox, one is designed for engaging even gears, the other for odd gears. Once a gear has been engaged, the system has already preselected the next one. After reaching the correct RPM, a clutch opens and at the same time the other one closes, so that the traction force is not interrupted.
Disposal	The procedure laid down in Directive 2000/53/EC and the implementation standard.
DRS	Drag Reduction System, adjustable flap on rear diffuser which reduces aerodynamic drag when open.
E-Diff 3	Evolved electronic differential integrated with the F1-Trac traction control.
EBD	(Electronic Brake-Force Distribution) Electronically-controlled brake-force distribution.
ECU	Electronic Control Unit.
EPB	Electric Parking Brake: the system operates by means of an ECU and an electric motor on the rear brake shoes.



Abbreviation	Meaning
ESC	Electronic Stability Control Consists of two systems: VDC and F1-Trac.
F1-Trac	Traction control derived from the technologies used in the racing sector. The system can estimate the maximum available grip in advance by continuously monitoring the relative wheel speed and using an auto-adaptive operating logic. Comparing this information with the vehicle dynamics model stored in the control system, F1-Trac, optimises the vehicle behaviour by controlling engine torque delivery.
FBP	(Ferrari Brake Prefill) System that eliminates the distance between the brake pads and discs by applying slight pressure to the braking system as soon as the accelerator pedal is released just before braking. This results in more immediate brake response.
Homologation	The procedure laid down in Directive 2007/46/EC and the implementation standard.
Launch Control	Strategy for performance standing starts.
Manettino	The driving mode control switch on the steering wheel that allows the driver to use vehicle potential in a quick, intuitive way.
Park Lock	Automatic DCT gearbox park lock. When the engine is off, a mechanical lock is automatically activated to prevent the vehicle from moving if the electric parking brake is not activated.
SSC	Side Slip angle Control, electronic side slip angle control system, to ensure the maximum grip available in all situations.
TFT displays	Multifunction colour displays on the instrument panel that provide vehicle information.
TPMS	Tyre Pressure Monitoring System (optional). Using special sensors fitted inside the wheel rims next to the air valve, the data measured is sent to an ECU. The data and messages are displayed on the left TFT display.
Track (driving vehicle on)	Occasional usage of the vehicle for limited periods of time on circuits closed to public traffic to make use of the full potential of the vehicle, practice driving techniques or for learning. The vehicle is NOT intended for more frequent and continuous usage on the track.



Abbreviation	Meaning
Traction power	Force exerted by the vehicle on the road surface through the wheels; it indicates the grip.
VDC	Vehicle Dynamic Control performed through the braking system and engine torque.
Xenon headlights	Headlights on the front of the vehicle that produce a more intense beam by using a voltaic arc rather than an incandescent spiral.

Table of Contents 262



TABLE OF CONTENTS



Index

Symbols

12V power socket 181

A

Abbreviations 9

ABS 61

Activating Cruise Control 116

Activation of electronic alarm 20

Active aerodynamics 120

Active aerodynamics (DRS) 120

Active safety 45

Adaptive headlights 130

Adjusting display brightness 86

Adjusting the air vents 179

Adjusting the steering wheel 173

AFS2 130

Air conditioning and heating system 176

Air conditioning controls 176

Air recirculation 178

Alarm memory 22

Alarm system 134

Auto easy exit 140

“Auto easy exit” mode 140

Automatic gearbox 140

“Automatic gearbox” mode 140

Automatic Vehicle Holding 64, 153

Autopark Function 64, 153

Auxiliary Occupant Protection Systems 52

AVH function 64, 153

B

Backrest and seat cushion side width adjustment 169

Basic seat 166

Battery 224

Battery conditioner 228

Before a trip 132

Brake fluid 245

C

Capless filler neck 80

Carwash 154

Carwash procedure 154

Checking the battery 224

Child restraint systems 57

Chronometer 93

Chronometer operating 94

Chronometer screen page 93

Cleaning and care of the Alcantara upholstery 252

Cleaning and care of the leather upholstery 252

Cleaning the exterior 249



Cleaning the interior	252	Doors	74
Cleaning the parking sensors	99	“Doors, engine or luggage compartment lid open”	
Cleaning the vehicle	249	function display	103
Closing the engine compartment lid	76	DOWN-shifting	138
Closing the fuel filler flap	79	DOWN-shifting due to underrevving	138
Closing the luggage compartment lid	78	“DOWN” shift paddle	123
Clutch overheat alarm devices	230	Drive Away function	152
Collapsible spare wheel	220	Driver and passenger airbag operating	54
Configuration of vehicle parameters	86	Driver and passenger airbags	53
Consulting the manual	8	Driver-side power window	81
Consumption	31	Driving at night	142
Controls on the steering wheel	118, 120	Driving in fog	143
Controls overview	72	Driving in the rain	142
Coolant	244	Driving on mountain roads	143
Cruise Control (optional)	116	Driving on snowy or icy roads	144
CT OFF mode	119, 148	Driving style	10
D		Driving the vehicle	132
Day lights	128	Driving using the driving mode control switch	
DCT gearbox oil	243	(“Manettino”)	146
Deactivating Cruise Control	117	Driving with the “ABS” braking system	144
Deactivating the anti-lift alarm	22	Dual View Camera (optional)	115
Deactivation of electronic alarm	21	Duplicating the keys	19
Deformable body	44	E	
Dimensions	30	EBD	61
Disconnecting the battery	224	E-Diff 3	63
Display setting	86	Efficient gear shift indicator light	112
Dome light	131	Electrically-adjustable seat	168



Electrical system	31
Electric parking brake	64, 152
Electronic alarm	20
Electronic rev counter	83
Electronic Stability Control	62
Emergency engine start/stop	136
Emergency opening of fuel filler flap	79
Emergency opening of luggage compartment lid	78
Emergency release of the electric parking brake (EPB)	232
Emergency starting	226
Emergency tyre repair and inflation kit	206
Emissions	31
Engaged gear display	111
Engine compartment lid	76
Engine malfunction alarm devices	231
Engine oil	242
Engine RPM LED on steering wheel	110
ENGINE START	118
Environmental protection	10
EPB - Electric parking brake	64, 152
ESC	62
“ESCAPE” function	101
ESC OFF mode	119, 148
Exhaust system overheating alarm devices	229
External rear-view mirrors	174

F

F1-Trac	63
Failure of turn indicators and running lights	102
Fault display	101
FBP - Ferrari Brake Prefill	62
Ferrari CODE system	18
Flashing the headlights	126
Follow me home	130
“Follow me home” function	130
Front Lift	164
“Front Lift” system	164
Front parking sensors (activation/deactivation)	131
Fuel filler flap and neck	79
Fuel filler neck	79
Fuel inertia switch	60, 223
Fuel level	87
Fuel level gauge	87
Fuses	212

G

Gearbox display	110
Gear engaged	111
General remarks	4
Glossary	257



H

Hazard warning lights	129
Headlight washer	124
High beams	126
Horn	122
Horn control	122
How to fasten seat belts	48
How to use the tyres	247

I

Identification and homologation plates and labels	24
If the vehicle is stored for long periods	253
Indication of AVH system activated	111
Indication of Launch Control activated	111
Infotainment system	182
Instruments and gauges	82
Internal rear-view mirror	174

K

Key codes	14
“Key-Less” ignition system	134

L

LAUNCH button	155
Launch Control	155
Leather upholstery	252

Left TFT display	84
Left TFT display symbols	104
Level checks	240
Light bulbs	211
Lighting	126
Light switch	126
Locking and opening the doors from the inside	74
LOCK/UNLOCK	131
Low tyre pressure	66
Luggage compartment lid	77
Lumbar support adjustment	169

M

Main engine specifications	31
Maintenance	238
Maintenance of seat belts and pretensioners	51
Maintenance schedule	238
Manettino	118, 146
“Manettino” driving mode control switch	118
Manettino status	92
Manettino status screen page	92
Matt paintwork	250
Memorising the driver’s seat position	169
MENU screen page	86
Ministerial homologation	23



N

Neutral	138
“N” (Neutral)	138
“N” request	138

O

OK button	84, 85
Opening doors from the outside	74
Opening the engine compartment lid	76
Opening the fuel filler flap	79
Opening the luggage compartment lid	77

P

Parking Camera	114
Parking lights	127
“Parking” mode	111
Parking sensor failure	100
Parking sensors	97
Park Lock	154
Park Lock emergency release	234
Passenger compartment accessories	180
Passenger display (optional)	198
Passenger-side power window	81
Passive safety	44
Performance	31
Performance start	155

Pocket-change compartments	180
Power steering	144
Power steering system oil	244
Power windows	81
Pregnant women	47
Pretensioners	50
Push start	140

R

RACE mode	119, 147
Rain sensor	125
Rain sensor failure	125
Rear fog lights	129
Rear-view mirrors	174
Reconnecting the battery	225
Refilling	38
Remote control batteries	20
Replacing a fuse	212
Replacing a wheel	219
Replacing light bulbs	209
Replacing remote control batteries	20
Replacing the brake pads and discs	232
Right TFT display	112
Roof panel controls	131
Running-in	132



S

Safe driving	141
Satellite alarm system	23
Seat adjustment	166, 173
Seat belts	46
Seat heating	170
Seats	166
Sequential downshifting	138
Service	8
Side airbag operating	58
Side airbags	57
Side Slip angle Control (SSC2)	121
“Slow Down” function	229
Spare parts	7
Special recommendations	42
“Speed limit exceeded” message	96
Speed limit setting	96
Speedometer	113
Speedometer display	113
“Speedometer” screen page	113
SPORT 2 screen page	89
SPORT mode	119, 146
SPORT screen page	89
Start button	118
Starting the engine	137
Starting the vehicle	137
State of vehicle	91

STATUS	84
Steering wheel	173
“Stop and Go” function	97
Stopping the vehicle	139
Stop&Start	156
Stop&Start failure	162
Stop&Start system (optional)	156
Sun visors	181
Super Racing seat	171
Suspension damping control	145
Suspension damping delink button	150
Switching off the engine	139
System start-up	133

T

Telemetry Kit (optional)	95
Telemetry (optional)	95
Telephone function	196
Tilting the backrest	167
Tool bag	202
Toolkit	202
Tow hook	222
Towing	222
TPMS	65
TPMS failure	68
TPMS inactive	69
TPMS not calibrated	68
TPMS temporarily inactive	69



Transmission ratios	31
TRIP	85
TRIP A and TRIP B screen pages	93
TRIP A/B	95
TURBO screen page	88
Turn indicators	128
Twilight sensor	128
Tyre inflation pressure	33
Tyre puncture	67
Tyres	32
TYRES screen page	90
Tyre temperature and pressure monitoring system	65

U

Unfastening the seat belts	49
UP, DOWN, LEFT, RIGHT buttons	84
UP-shifting	138
UP-shifting due to overrevving	138
“UP” shift paddle	123
USB connectors	113
Use of the vehicle	10

V

VDA	84, 90
Vehicle Dynamic Assistance	90
Vehicle key homologation certificate	15
Vehicle keys	14
Vehicle status screen page	91
Voice commands and PTT (Push-To-Talk) function	197

W

Warming up the engine	136
“Warning: danger of ice” message	96
Warning lights on the panel	104
Warranty Booklet	7, 238
Weights	30
WET mode	119, 146
Wheel alignment check and adjustment	248
Wheel rims	32
While travelling	141
Windscreen and headlight washer fluid	246
Windscreen washer	124
Windscreen washer/wiper	123
Windscreen washer/wiper lever	123
Winter tyres	33

Equipment and options in FERRARI vehicle models may vary because of specific legal and market requirements. The information contained in this publication is therefore not binding in any way.

FERRARI reserves the right to make any modification to the vehicle models described in this manual, at any time, for either technical or commercial reasons.

Contact the nearest FERRARI Dealer for any further information you may require.

In the interests of efficiency and safety, as well as to preserve the value of the vehicle, we do not recommend modifying the equipment using non-approved parts.

Code no. **87424000**
Catalogue no. **5010/15**

EDITION
1st edition **May 2015**

EDITING
STAR s.r.l.
Alessandria - Italia

PRINTING
STAR s.r.l.
Alessandria - Italia



Technical Service Department
Via Abetone Inferiore, 4
41053 Maranello
Modena - Italia